

T-DRIVE

Part 2/2

User's manual



ANDILOG - BP62001 - 13845 Vitrolles Cedex 9 – France

ANDILOG / COM-TEN – 6405 49th Street North – 33781, FL, Pinellas Park - USA

Website: www.andilog.com

Contents

| | | |
|-------|--|----|
| 1. | Introduction..... | 4 |
| 1.1. | Presentation | 4 |
| 1.2. | Documentation | 5 |
| 1.3. | Definitions..... | 5 |
| 2. | Installation and start-up..... | 6 |
| 2.1. | Product opening | 6 |
| 2.2. | Recommendations before use..... | 6 |
| 2.3. | Start your system | 7 |
| 2.4. | How the T-Drive works | 14 |
| 3. | Movement controls | 15 |
| 3.1. | Controls | 15 |
| 3.2. | Travel configuration | 17 |
| 3.3. | Configuration of the test start | 20 |
| 3.4. | Moving at high speed | 21 |
| 3.5. | Reset the position to 0..... | 21 |
| 3.6. | Units..... | 21 |
| 3.7. | Change the language | 22 |
| 3.8. | Drivepack digital inputs..... | 22 |
| 3.9. | The Drivepack's digital output | 22 |
| 4. | Measurement with T-Drive..... | 24 |
| 4.1. | Main measurement screen..... | 24 |
| 4.2. | The touch areas of the measurement screen | 25 |
| 4.3. | Main menu..... | 26 |
| 4.4. | Do the Zero or Tare..... | 26 |
| 4.5. | Backlighting..... | 27 |
| 5. | Start your measurements | 28 |
| 5.1. | Start a measurement | 28 |
| 5.2. | Status indicator | 29 |
| 5.3. | Curve display area..... | 29 |
| 6. | Change the displayed information..... | 31 |
| 7. | Set a limit or thresholds..... | 33 |
| 7.1. | Activate / Deactivate..... | 33 |
| 7.2. | Sensor tab | 33 |
| 7.3. | Choice of the value to which the limit applies | 33 |
| 7.4. | Setting limit values..... | 34 |
| 7.5. | Stop the building on a limit..... | 34 |
| 8. | Set up the graph and the tests..... | 35 |
| 8.1. | Test tab | 35 |
| 8.2. | Configuration of test conditions | 35 |
| 9. | Setup calculations | 38 |
| 9.1. | Choice of calculations | 38 |
| 9.2. | Action following a calculation | 39 |
| 10. | Storage of results and statistics | 40 |
| 10.1. | Statistics configuration | 40 |
| 10.2. | Save values..... | 41 |
| 11. | Communication with a computer | 42 |

- 11.1. RS232 or Serial link 42
- 11.2. USB connection..... 44
- 11.3. Bluetooth link..... 45
- 11.1. Analog link 45
- 11.2. Data Stick (Option)..... 45
- 12. Digital and pedal inputs and outputs 48
 - 12.1. Centor Touch releases 48
 - 12.2. Inputs and pedal 49
- 13. General parameters..... 50
 - 13.1. Sounds 50
 - 13.2. Eco mode 50
 - 13.3. Food management..... 50
 - 13.4. Screen orientation 50
 - 13.5. Language..... 50
- 14. Maintenance..... 51
 - 14.1. General 51
 - 14.2. Setting the clock: 51
 - 14.3. Pathways..... 52
 - 14.4. Factory configuration..... 52
- 15. T-Drive configuration examples 53
 - 15.1. Protection against overflow 53
 - 15.2. Peel test 55
 - 15.3. Cable breakage 56
- 16. Annexes 58
 - 16.1. Acquisition software 58
 - 16.2. Interface cables..... 58
 - 16.3. Protector - Safety enclosure 58
 - 16.4. Error messages 59
 - 16.5. Factory configuration..... 62
 - 16.6. Connections 64
 - 16.7. Dimensions 66

| Review | Date | Description |
|--------|----------|--------------|
| Rev 1 | Feb 2020 | New document |

1. Introduction

1.1. Presentation

Thank you for choosing the T-DRIVE CC test machine manufactured by ANDILOG / COM-TEn to perform your force measurements.

This system is the result of over 30 years of experience in force and torque measurement. This system integrates the latest technologies available to offer you unequalled performance and quality of measurement.

With a completely redesigned graphical user interface, the T-DRIVE is intuitive and easy to use. This user manual will guide you through the setup and get your first measurements. Then, this manual covers the advanced features of the frame allowing you to perform more complex tests and automate your results.

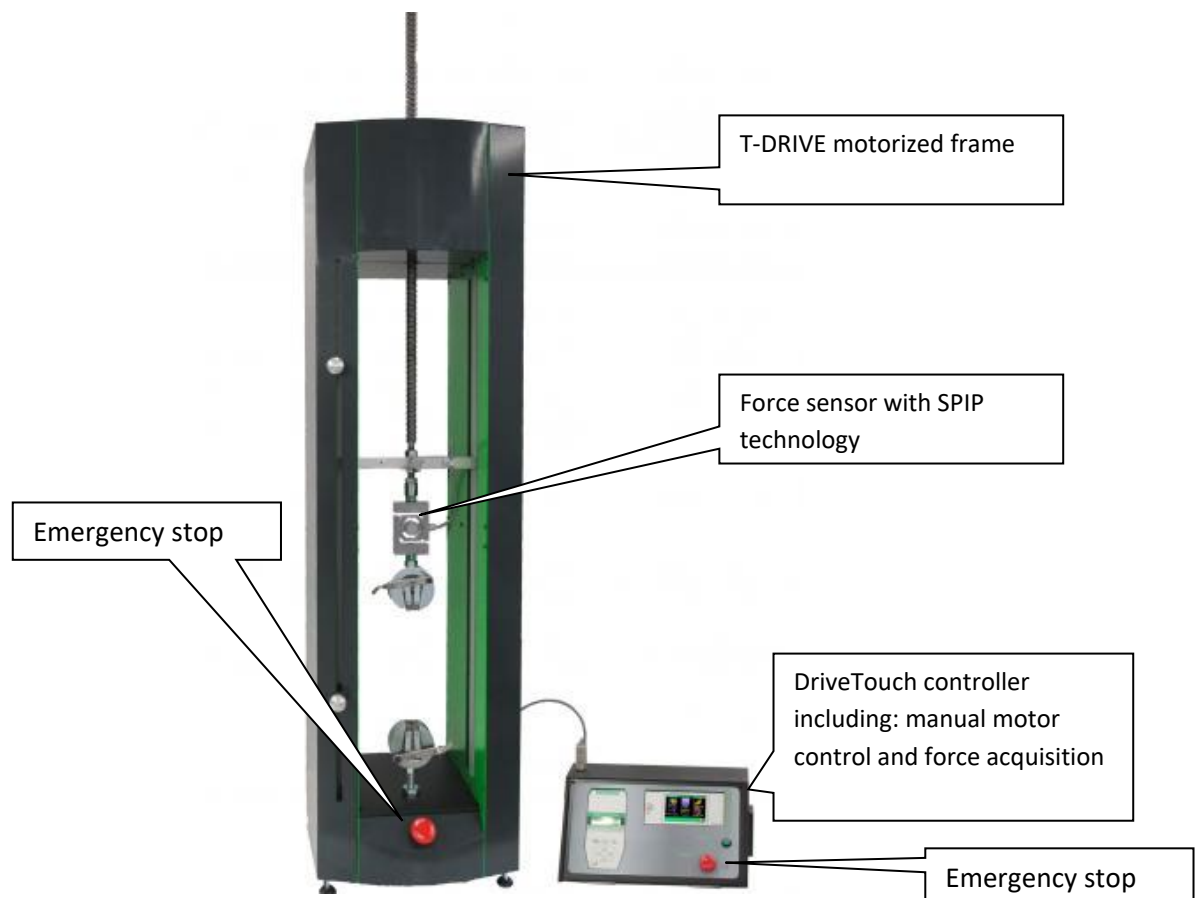

1.2. Documentation

This manual provides information on:

- System configuration and setup before starting tests
- Instructions for testing and execution

Refer to the safety and installation manual for information on the:

- System specifications that are required for the installation of your test system
- Handling operation (lifting and moving) of your system to its final location
- Initial installation of system components
- Maintenance operations

Please refer to the CALIFORT software user manual for information on how to install and set up automated tests and how to use the software.

1.3. Definitions

To facilitate the understanding of this manual, some definitions of terms frequently used throughout this manual.

1.3.1. SPIP

The SPIP is a technology developed by Andilog allowing the automatic recognition of external sensors by our systems. This technology allows to store inside the sensor the parameters of capacity, serial number and calibration.

1.3.2. Calibration

The systems are delivered calibrated by Andilog Technologies with a COFRAC calibration certificate. It is generally recommended to calibrate force measurement instruments once a year, unless there is a different internal procedure. Andilog Technologies guarantees at each calibration a complete verification of the instrument as well as an adjustment of the calibration to guarantee a perfect accuracy.

2. Installation and start-up

Refer to the safety and installation instruction - When opening the product. Check that the system has not been damaged during transport. In case of doubt, contact ANDILOG TECHNOLOGIES in order to obtain additional information to verify the proper functioning of your measuring system.

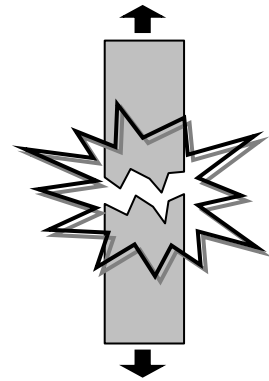

2.1. Product opening

The T-DRIVE CC system is supplied with:

- An external sensor
- A DriveTouch controller
- Califort software (sent by email)
- A calibration certificate
- Power cables and connection cables between components

2.2. Recommendations before use

2.2.1. Sensor

Despite the overload protection provided by this instrument, the application of a force greater than the capacity of the transducer can damage the system. The instrument will lock up if its capacity has been exceeded 10 times. You will then have to return your sensor to ANDILOG Technologies to check that it is working properly.

It is important that the measured values are generally below 90% of the sensor's capacity. Constant use of the load cell beyond 90% of its capacity can result in premature wear of the load cell. When the load cell is used on a motorized frame, it is necessary to program the frame to stop when the force approaches the maximum capacity of the load cell. This limit must take into account the fact that at high speed a frame does not stop immediately and the risk of damaging the sensor is high due to the inertia of the motor.

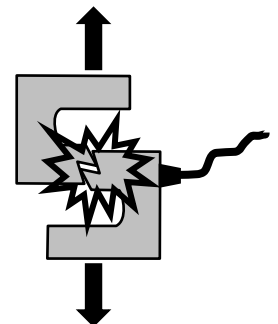

2.2.2. Precautions during testing

Most of the tests performed with Andilog Technologies instruments are destructive tests. The hazards associated with this type of testing require that our instruments be used by experienced and trained operators. Due to the nature and use of the equipment sold by Andilog, the purchaser's acceptance of Andilog Technologies' products constitutes acceptance of the risks and damages that may result from the use of Andilog's instruments.

2.2.3. Environmental conditions

- Operating temperature: 0 to 35° C
- Storage temperature: -20 to 45° C
- Relative humidity: 5% to 95%, non-condensing
- Maximum altitude of use: 3 000 m

2.2.4. Warranty

Subject to the conditions below, Andilog Technologies warrants to the purchaser that it will repair or replace at no charge new instruments sold subject to normal use and maintenance. This warranty applies if the purchaser detects a defect in workmanship or materials during a period of one (1) year from the date of shipment.

The conditions of application are:

- ANDILOG Technologies has been notified in writing of the defect before the end of the warranty period
- Products are shipped to Andilog Technologies with prior agreement from Andilog Technologies
- All transportation costs are paid by the buyer
- The products have been used and maintained under normal conditions of use

Any repair or replacement made by the seller outside the agreement of Andilog Technologies will void the warranty.

In no event shall Andilog Technologies be liable for any damages, business interruption, or loss of production due to the purchase, use, or failure of our products. And this even if Andilog Technologies has been informed of the possibility of such damages.

The accuracy of our devices is guaranteed at the time of shipment at the value indicated in our documentation or offers.

If products are damaged during shipment, notify the carrier and Andilog Technologies immediately.

The warranty is void in case of accident, misuse or abuse.

Calibration, overloaded sensors, consumable parts such as batteries are not covered by the warranty, unless the damage is due to a material or manufacturing defect.

2.3. Start your system

2.3.1. Connecting the DriveTouch controller

- Place the DriveTouch on the workbench or table next to the test system
- Connect the power cord to the DriveTouch controller and plug it into your power source.

- Connect the umbilical cable between the DriveTouch and the T-DRIVE test bench. The cable is equipped with notched connectors: Align the connectors and push the cable into the connector. Turn the connector collar 90 degrees to the right to lock the connection.

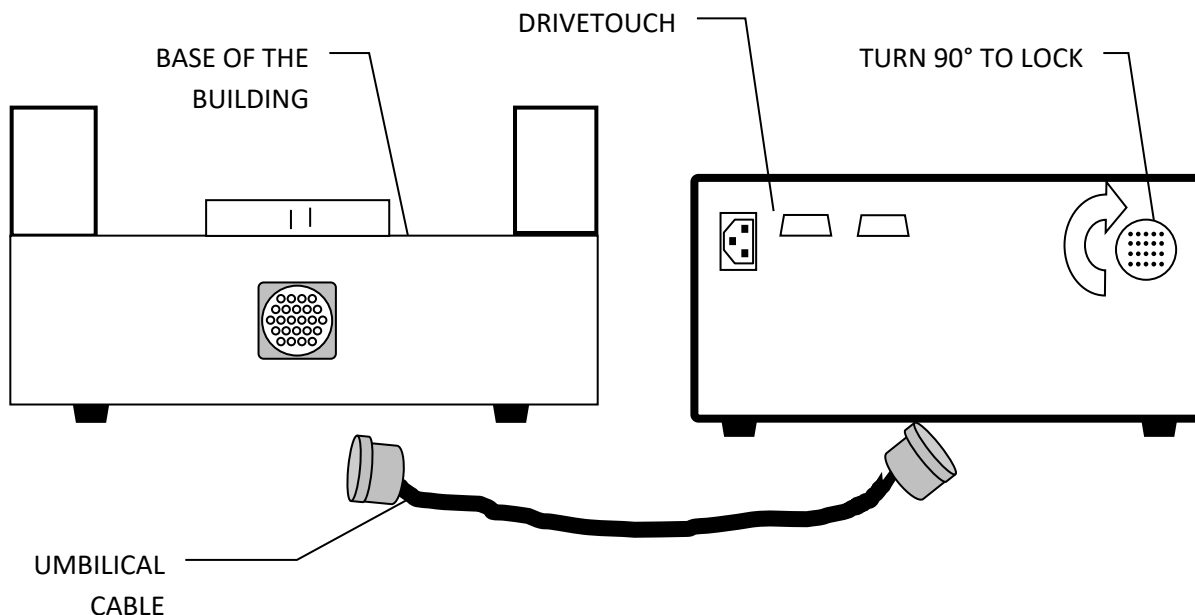

2.3.2. Mount the sensor

Remove the mechanical stops from the center crossbar, install the load cell according to the general mounting guidelines (defined in the following paragraphs), pass the cable through the cable gland and connect the connector to the DriveTouch controller

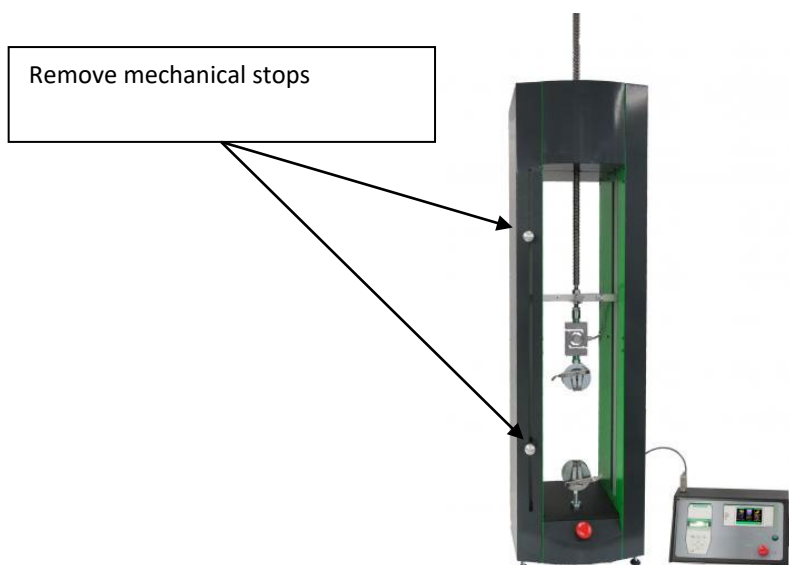

2.3.2.1. Important precautions during assembly

Handle the sensor with care and make sure the sensor cannot be overloaded

2.3.2.2. General mounting guidelines

The forces to be measured must act precisely on the transducer in the axis of measurement. Torsional moments and eccentric loads can cause measurement errors and destroy the sensor.

Screws and connecting elements must be screwed into the sensor in such a way that the elements do not touch the strain gages of the sensor. The strain gages are protected by a plastic coating, which offers optimum protection against the influence of changing environmental conditions. In order not to impair the protection and to ensure a long-lasting function of the load cell, this protection (sealing compound) must not be damaged, otherwise the load cell will be destroyed.

NOTE: The weight of the attachment or accessory mounted to the load cell must not exceed 5% of the maximum capacity of the load cell.

Location of strain gauges - 10N to 1000N sensor:

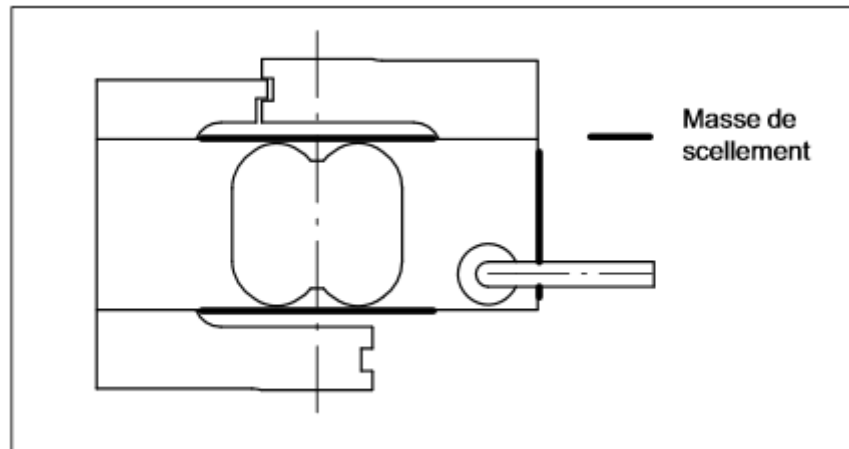

Note: Do not loosen the Allen screws or the load cell calibration will become invalid.

Location of gauge protections - 2000N to 5000N sensor:

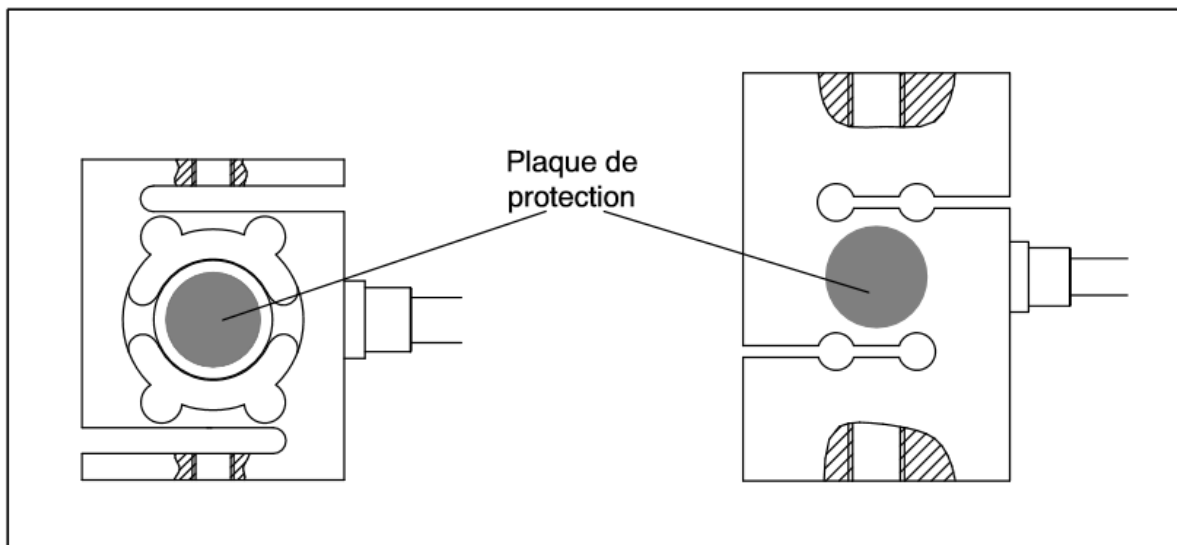

Orientation of the sensor when installed:

- 10N to 1000N sensor

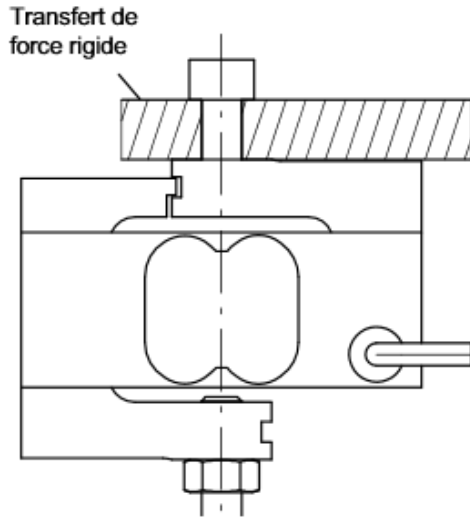

Correct

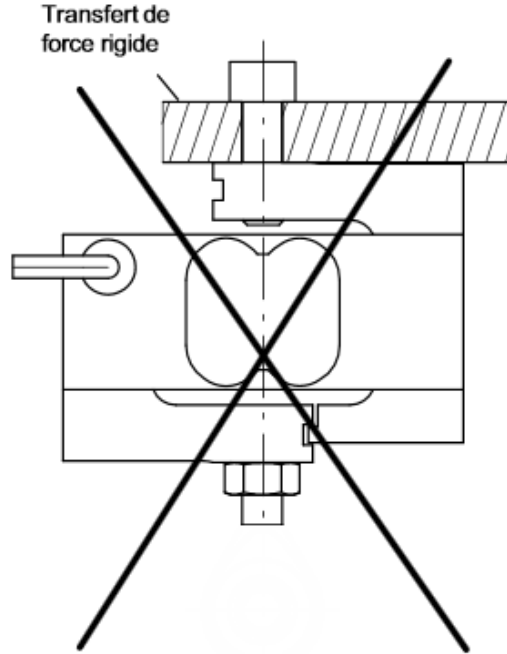

Incorrect

- 2000N to 5000N sensor

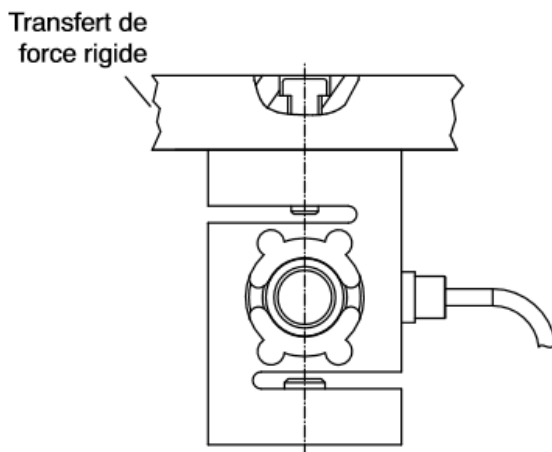

Correct

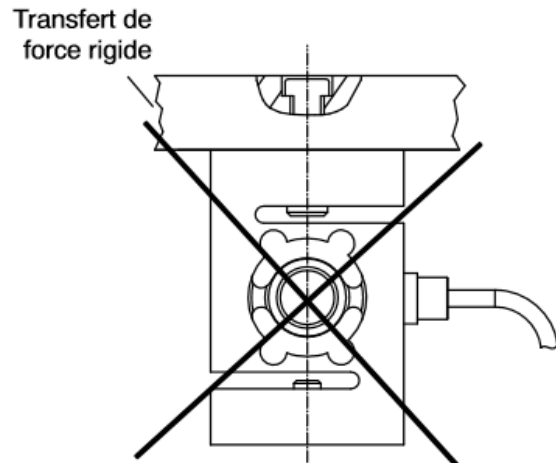

Incorrect

2.3.3. Turn on the power

Plug in the power cord, turn the emergency stop button to unlock it and press the switch.

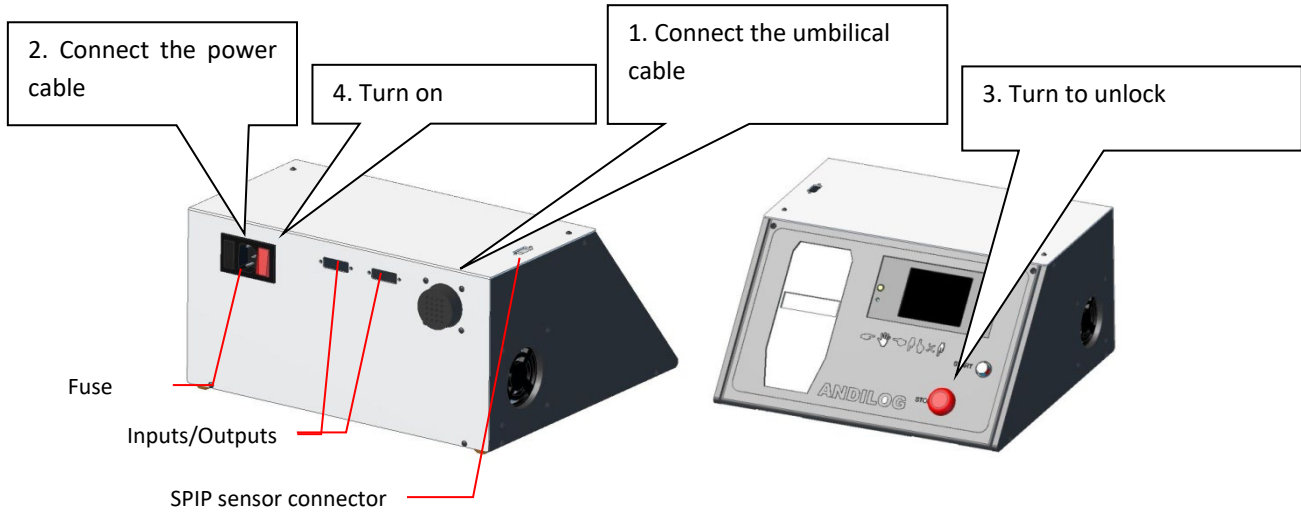

2.3.4. Startup

The DriveTouch controller of the T-DRIVE test machine consists of two separate controls:

- Motor control of the frame, called DRIVEPACK: allows to control the movement of the motorized column: movement, speed, stop...
- Acquisition of measurement, called CENTOR TOUCH DUAL: measurement of the force according to the displacement.

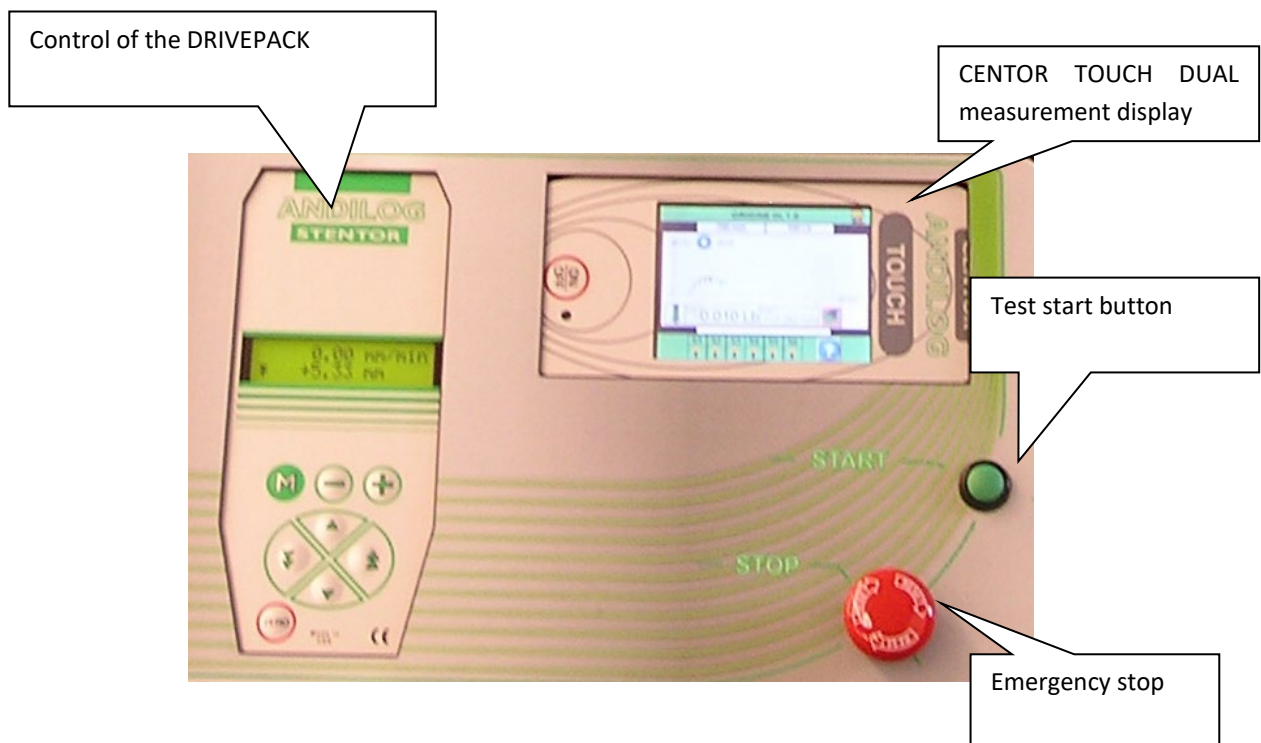

By pressing the switch on the side of the DriveTouch controller and if the emergency stop is not pressed, the Drivepack control will turn on. To start the CENTOR TOUCH DUAL display, **press the on/off button**: an information screen indicating the status of the instrument appears for 5 seconds, then the main measurement screen is displayed.

Information screen at startup :



Battery status: indicates the battery charge level and whether the device is connected to the mains.

Current date: Displayed in the format Europe: " DD / MM / YYYY " or US: " MM / DD / YYYY ", which can be accessed in the Maintenance menu (See chapter " Maintenance ")

Software version: This line indicates the version of the embedded software installed on the controller.

Internal and external sensor: Indicates the type of sensor connected (force, torque, displacement or angle) to your test machine and its operating status.

- A red "X" symbol indicates that the sensor is not recognized or has a serious problem. See chapter [Maintenance](#) for more information.
- A red exclamation mark! Indicates a minor warning on the sensor, such as overload or calibration date exceeded.

Sensor Information: At start-up, the CENTOR TOUCH display detects whether internal or external sensors are connected. External sensors are connected to the CENTOR TOUCH via the special connector, called SPIP.

Sensor information is displayed in the green rectangle in the center of the screen:

- Channel V1 for internal or V2 for external
- Date of next calibration
- Number of overloads

If the measurement window does not appear: While displaying the low battery indication, CENTOR TOUCH runs internal tests. If, during these tests, problems are detected, the **Autotest** icon is displayed at the bottom left of the screen. See chapter [Annexes](#) for the meaning of the error messages.

If the error detected makes the measurement impossible (major error such as a defective sensor for example), the device will remain blocked on this display and it will be impossible to perform any other measurement. In this case, contact the ANDILOG Technologies team to know the return procedure.

If the error detected does not make measurement impossible (minor error such as low battery level or overload), you can go to the main screen by pressing the **Measure** button at the bottom right.

2.4. How the T-Drive works

The T-Drive with its DRIVETOUCH controller is designed around two independent systems, the CENTOR TOUCH DUAL (for measurement acquisition) and the DRIVEPACK (for motor commands).

- DRIVEPACK frame control: allows to control the movement of the motorized column: movement, speed, stop...
- CENTOR TOUCH DUAL measurement: force measurement as a function of displacement.

These two systems are configured separately and each has its own control command. Nevertheless, these two systems communicate with each other using digital inputs and outputs.

The general principle of operation is as follows:

- Drivepack configuration of the frame movement: up and down speed, maximum movement, mechanical movement stops, cycles, actions when the frame meets a stop
- Configuration with the Centor Touch Dual of the acquisition of the force according to the displacement, calculations (rupture, average...), force limits.
- Configuration of the Centor Touch Dual outputs so that the Drivepack performs specific actions (stop, return...) at particular moments of the measurements. The most classical configurations will be discussed in [Exemples de configuration du T-Drive](#) for example: stop of the frame when the sensor capacity is exceeded, stop on limit, return on break, Topload test...

This manual is therefore built in the same way. We will first discuss the configuration of the movement of the motorized column, then the configuration of the acquisition of measurements and finally the communication between the two systems. In the last part, detailed examples of current configurations are presented.

NOTE: On the other hand, the CALIFORT control and command software allows you to combine these 2 commands for the configuration and parameterization of your tests.

3. Movement controls

The movement of the motorized bi-column test machine is done by means of the DRIVEPACK control below. It allows to adjust the behavior of the system during the ascent and or descent.



3.1. Controls

The keys of the control have different behaviors depending on the mode you are in. There are two modes:

- Normal mode
- Configuration mode

3.1.1. Functions in Normal mode

| KEY # | NAME | DESCRIPTION |
|-------|------|-------------|
|-------|------|-------------|

| | | |
|---|----------------------|---|
| 0 | Display | Displays real time information about the T-Drive: displacement, speed, error, ... |
| 1 | MENU button | Access to the configuration mode |
| 2 | + button | No function |
| 3 | Button - | No function |
| 4 | Up button | Start up of the frame at the preset speed |
| 5 | Down button | Start the frame down at the preset speed |
| 6 | Quick rise button | Start up of the frame at the speed of 350 mm/min |
| 7 | Quick descent button | Start of the frame downwards at the speed of 350 mm/min |
| 8 | Reset button | Resetting the displacement value |

PRESSING ANY KEY ON THE CONTROL UNIT WHILE THE FRAME IS MOVING CAUSES THE MOTOR TO STOP

A LONG PRESS (3 seconds) ON THE ZERO KEY RESETS THE CONSOLE

3.1.2. Functions in configuration mode

| KEY # | NAME | DESCRIPTION |
|-------|---------------------|---------------------------------|
| 1 | MENU button | Access to Normal mode |
| 2 | + button | Go to next parameter |
| 3 | Button - | Go to previous parameter |
| 4 | Up button | Increments the parameter |
| 5 | Down button | Decreases the parameter |
| 6 | Quick rise button | Increases the parameter quickly |
| 7 | Fast descent button | Decreases the parameter quickly |
| 8 | Reset button | No function |

Note: The displacement value can be set to zero at any time when the motor is stopped. The displacement origin is therefore 'relative'. To have a fixed origin see the 'Raz table' option.

3.1.3. Emergency stop

The machine is equipped with an emergency stop button with mechanical lock, located on the right side of the front panel. The emergency stop button allows the machine to be stopped by a total cut-off of the power supply. To start the machine again, the emergency stop button must be unlocked.

Caution: If the machine is stopped by the emergency stop, the displacement value may be incorrect, so it is necessary to check the displacement value when restarting.







This does not apply when the machine is switched off at the end of the operation via the switch with the motor stopped. In this case, the value of the displacement is kept in memory and displayed at the time of powering up.

3.2. Travel configuration

The Drivepack allows you to configure the up and down movements of the motorized frame. The configuration of the up and down movements are separate and have independent parameters. For each direction of movement you can configure the following:

- Speed
- Maximum displacement
- Action on maximum displacement
- Action on mechanical stop
- Travel time
- Action on end of travel time
- Cycles

Navigating through the menus, changing parameters or modifying a value is always done in the same way whatever the parameter:

- The configuration menu is accessed by pressing the  key.
- Moving from one menu to another using the + and - keys.
- To exit the menu and confirm the configuration, press the  key.
- Change parameters or values using the keys , , , .





3.2.1. Menu architecture

- Climbing speed
- Descent speed
- High mechanical stop
- Low mechanical stop
- High travel stop
- Type of stop (fast or precise)
- Low travel stop
- Type of stop (fast or precise)
- Time stop mounted
- Time stop descent
- Climbing break
- Downhill break
- Cycles
- Pedal
- Entry 1

- Input 2
- Output
- Units
- Language

The menu is dynamic, i.e. if one of the stops is inactive, then its setting menu is not proposed by Drivepack.

3.2.2. Speed configuration

The first two menus allow you to set the up and down speed separately. Use the  and  keys to increase or decrease the speed in steps of 0.05mm/min and the  and  keys to increase the speed in steps of 5mm/min. A long press on these keys will increase the values more quickly.

Caution: The frame speed is adjustable. During testing, especially during compression, too high a speed may prevent the sensor protection system from being triggered in time if you exceed the maximum capacity.

3.2.3. The displacement stops

A travel stop is a fixed point where the moving center crosspiece of the motorized frame will stop during its travel. The upper travel stop corresponds to a travel limit when the frame is moving upwards and the lower travel stop corresponds to a travel limit when the frame is moving downwards.

If multiple limits are configured in Drivepack, the first limit encountered by the rack will be executed and the other limits will be ignored.

There are 3 different configurable limits in Drivepack: mechanical, displacement and temporal. For each limit, it is possible to configure 4 actions for the frame:

- Inactive : the frame does not take into account the limit
- Stop the frame stops when it meets this stop
- Reversing machine The frame moves in the opposite direction at the set speed
- Inv temp the frame starts again in the opposite direction of movement at the speed set after a pause of X seconds set in the Pause meme.

Multiple stops can be configured for a single test. It is strongly recommended to use mechanical stops as safety stops in order not to destroy the sample, the fixtures or the sensor. Therefore, time or displacement stops are usually used to end the test.

The mechanical stops: There are two mechanical stops on the side of the frame as shown in the picture below. They allow to adjust the maximum stroke of the slide. They are often used as a safety device during testing. It is strongly recommended to leave them always active.

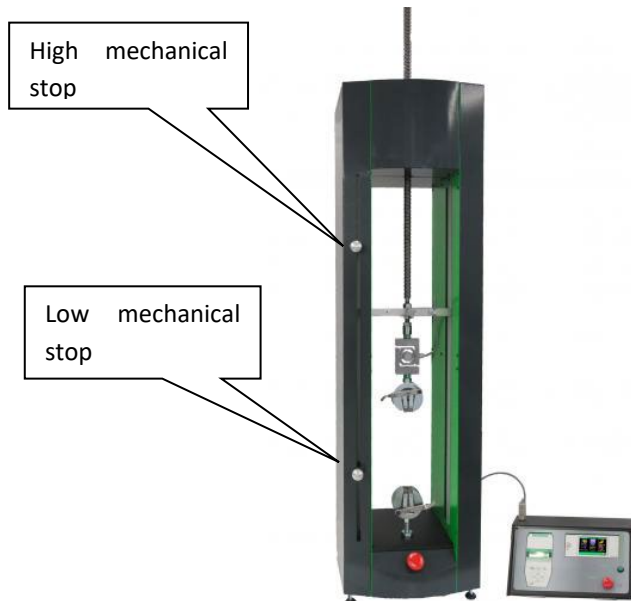

You can set these limits separately in the "Butee Capt \uparrow " and "Butee Capt \downarrow " menus.

Note: These limits, if enabled, are taken into account when manually moving at high speed.

Note: Adjust the position of the stops if the accessories or sensor are replaced by others, to take into account their dimensions.







Position stops: They are defined by a displacement in millimeters. If they are active, a distance configuration menu appears in Drivepack and can be accessed by pressing the + key once. These limits can be configured in the menus "Stop pos \uparrow " for the stop when moving upwards and the menu "Stop pos \downarrow " when moving downwards.

Note: The displacement value set for this limit is relative to the 0 position of the frame, which can be reset to 0 at any time using the key . The upward movement is positive and the downward movement is negative.



Example of configuration, if you enter the following parameters in the Drivepack:

- Speed \uparrow 150 mm/min
- Speed \downarrow 50 mm/min
- Butee pos \uparrow Arret
- Butee pos \uparrow 60mm
- Butee neg \downarrow Reverse
- Butee neg \downarrow -30mm
- All other stops are inactive



If you return to Normal mode, there are several possibilities:

- If you press the  key to reset the frame movement to 0 and then press the  key, the T-Drive will move down 30mm at a speed of 50mm/min. Then it will move up 90mm (60mm - (-30mm) = 90mm) at a speed of 150mm/min. And finally it will stop at this position of +60mm
- If you do NOT press the  key and the position of your T-Drive is for example +10mm then when you press the  key, the T-Drive will move down 40mm (from +10mm to -30mm) at a speed of 50mm/min. Then it will move up 90mm (from -30mm to +60mm) at a speed of 150mm/min. And finally it will stop at this position of +60mm
- If you press the  key to reset the frame movement to 0 and then press the  key: The T-Drive will then move upwards a distance of 60mm at a speed of 150mm/min. Then it will stop at the 60mm position.

Note: These limits, if enabled, are **NOT taken into** account when moving manually in high speed.

Time stops: Time stops are defined by a travel time in seconds. If they are active, a time configuration menu appears in Drivepack and can be accessed by pressing the + key once. These limits can be configured in the "Time limit  " menu for the upward movement of the stop and in the "Time limit  " menu for the downward movement of the frame. The operation is identical to the position stops.

Note: These limits, if enabled, are **NOT taken into** account when moving manually in high speed.



Pause: If at least one of the above stops is set to "Inv temp", then the menus "Pause  " and "Pause  " are available in Drivepack. These menus define the waiting times, in seconds, when the frame encounters a stop before it starts again in the opposite direction.

Note: The system may appear to be inactive when using the "Pause" function, but will begin to move without notice once the function is complete. Do not attempt to adjust accessories or remove samples until the test is complete.

Cycle: If at least two stops are set to "Reverse" or "Temp. inv", then the "Cycle" menu is available in Drivepack. This menu allows you to define the number of times the frame will cycle up and down between the reversing stops. This number of cycles can be set from 1 to 255.

3.3. Configuration of the test start

There are two ways to start the movement of the motorized frame:

- Pressing the keys  and  will start moving the frame up or down.
- A long press on the green button on the front of the controller can start the T-Drive moving. This button can be configured in different ways as needed as follows.

Configuration of the green Start button on the front of the controller: To configure this button, you have to go to the Drivepack menu and then to the "Action Pedal" menu. You then have several choices:

- Inactive No action
- Dem neg starts the frame downwards
- Dem pos starts the frame upwards
- Stop Stop the frame in its movement
- RESET Reset the position value to zero (equivalent to the  key)

Once the test is started, the Drivepack display shows :

- The speed of movement
- The direction of travel
- Real time position of the frame

Example:



↑ 100.0 mm/min
+ 12.00 mm

In this example, the frame moves upward at a speed of 100mm/min and is 12mm above 0.

To stop the T-Drive, press any button on the Drivepack control.

Note: If the T-Drive reaches one of the stops during its movement, it will then execute the configured action (Stop, return...).

3.4. Moving at high speed



It is possible to manually move the rack in high speed using the Drivepack command, for example to place the rack at the start point of the test. To do this, use the keys  and  to move up or down. If the key is released, the rack stops.

Note: In fast travel mode, only the mechanical stops are active. The other stops are not taken into account by the frame. This mode should only be used to move the ram to its original position. It should not be used for testing.

3.5. Reset the position to 0

To reset the T-Drive position to 0, press the  key when the motor is stopped.

3.6. Units

This menu allows you to choose the unit of speed and displacement display. Use the  and  keys to toggle between mm/min and in/min.

3.7. Change the language

The last menu allows you to change the language of Drivepack. The available languages are :

- French
- English
- German
- Spanish

3.8. Drivepack digital inputs

The Drivepack motion controller has 2 configurable digital inputs. These two inputs are accessible on the 15-pin connector on the side of the controller (see the "Appendix" chapter for details of the input numbers on the connector). They allow the rack to perform actions on command from another device.

For example, they can be used to stop the frame when the controller detects a break or reaches a limit. For example, it is possible to perform a stop on force threshold or a stop on breakage.

The different actions possible on the activation of its inputs:

- Inactive no action
- Dem neg starts the frame downwards
- Dem pos starts the frame upwards
- Stop stops the frame in its movement
- RESET Resets the position value to zero (equivalent to the  key)
- Reversing machine The frame moves in the opposite direction at the set speed
- Inv temp the frame starts again in the opposite direction of travel at the speed set after a pause of X seconds set in the Pause menu.
- RS232 The Drivepack sends the information 'Digital input' on its RS232 output to the Califort software. If you are not using Califort, this action has no effect.

When used with the CALIFORT software, the software takes control of the digital inputs.

3.9. The Drivepack's digital output

The Drivepack motion controller has a configurable digital output. This output is accessible on the 15-pin connector on the side of the T-Drive (see appendix for details of the output number on the connector). It is used to inform another device of an event that has occurred.

The different events that can trigger this output are:

- Inactive : the output is never triggered
- Butee Pos. a high stop (mechanical, position, time)
- Butee Neg. a low stop (mechanical, position, time)
- Error : security error, motor error, ...
- End of test End of test : this is the end of the last cycle

When used with the CALIFORT software, the software takes control of the digital output.

4. Measurement with T-Drive

Once you've set up the moves you want to make with the T-Drive, we'll now move on to how the Centor Touch Dual works, allowing you to make your force measurements.

4.1. Main measurement screen

Once you have passed the startup screen, the main measurement screen will appear as shown below. Depending on the options configured in the T-Drive, some information may or may not appear on your system.

NOTE: The configurations described here are those of the manufacturer, prepared by ANDILOG TECHNOLOGIES for delivery.

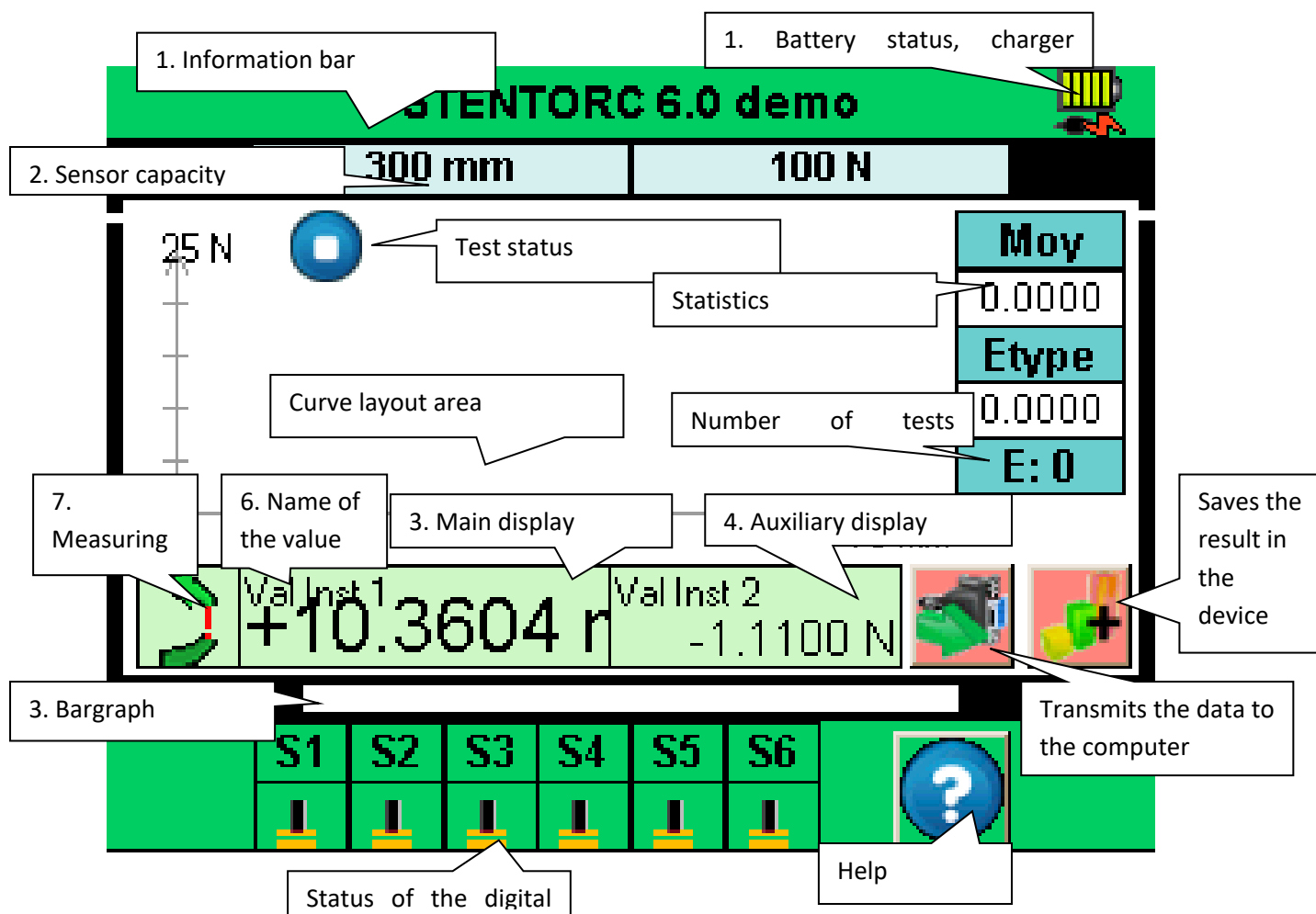

1 - Information bar: the name of the device appears in this bar as well as the battery icon: pictogram indicating the state of the battery supply via 4 horizontal lines which symbolize respectively 25%, 50%, 75% and 100% of the power. Pressing this area takes you to the main menu.

2 - Sensor capacity: the maximum capacity of each sensor and its unit of measurement are displayed at all times.



3 - Bar graph : A moving black line represents the force applied in real time. If the Bar graph is completely black, it means that the force applied is close to the full capacity, CAUTION there is a risk of overload! If the limits are activated, the Bargraf changes color according to the value read (see paragraph " [Régler une limite ou des seuils](#) ")

4 - Main display : A lot of information can be displayed in this window (current value, maximum, minimum, calculation...). See the configuration screen for more details.

5 - Auxiliary display area: A lot of information can be displayed in this window (current value, maximum, minimum, calculation...). See the configuration screen for more details.

6 - The name of the data displayed in the main and auxiliary displays is shown in the upper left-hand corner of each screen. We will see in [Modifier l'affichage de l'écran de mesure](#)How to change the value displayed is described in section 6.

7 - Direction of measurement of the sensor: A small mnemonic symbol indicates the direction of the force

exerted on the sensor  for voltage and  for compression.

4.2. The touch areas of the measurement screen

Each area of the measurement screen provides access to the controller's configuration menus.

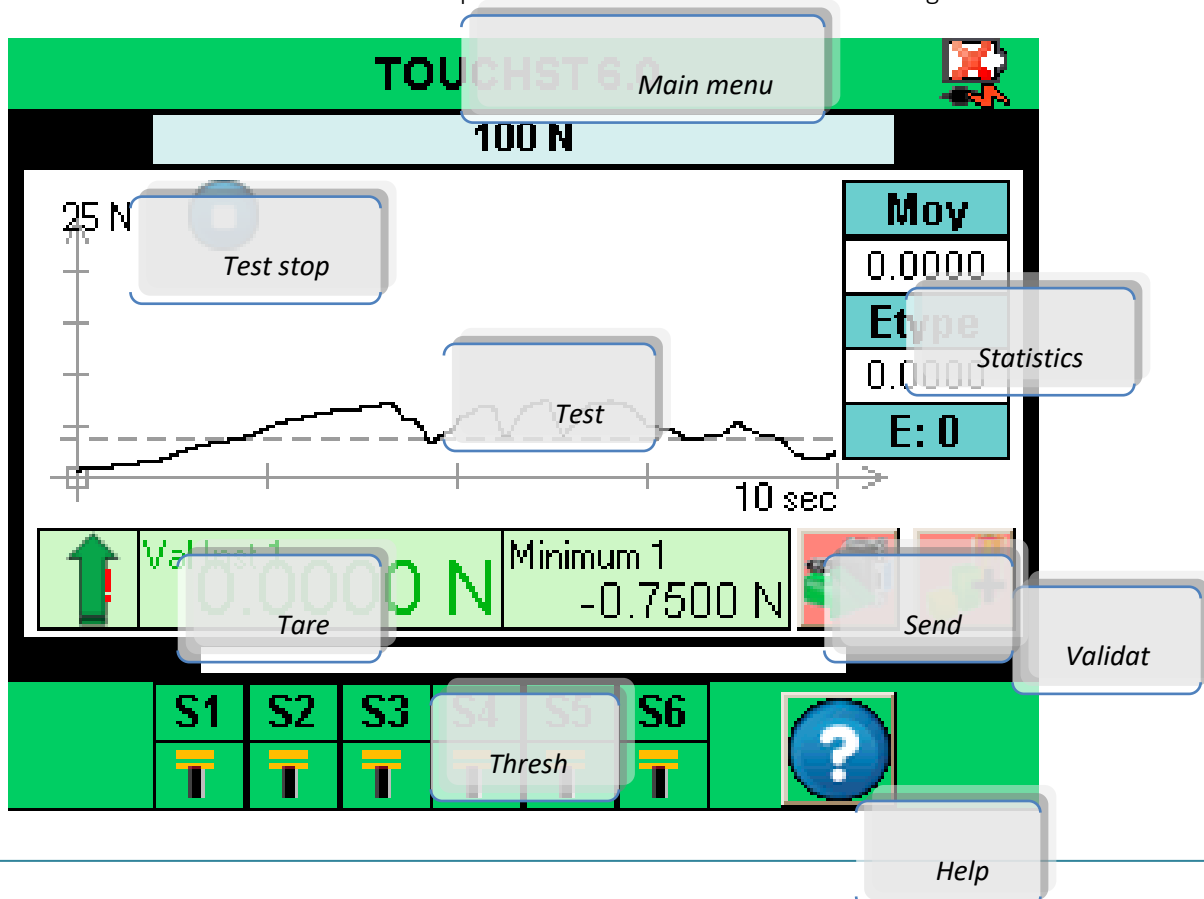

4.3. Main menu

To access the main menu, press the green bar at the top of the controller's measurement screen. The main menu appears:

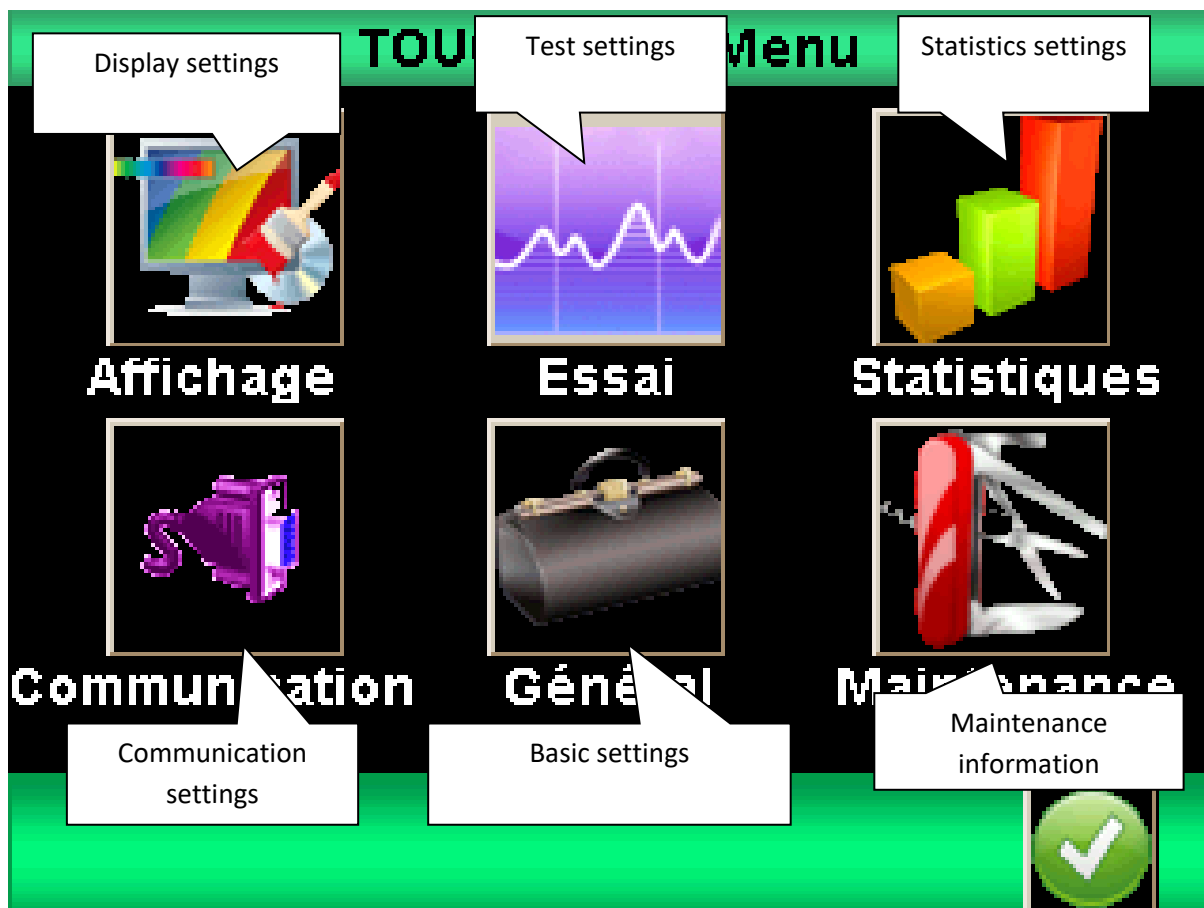

4.4. Do the Zero or Tare

Before each measurement it is important to tare or zero the sensor. By default, the green Start button on the front of the T-Drive is configured to reset the force and displacement to 0 and start a test. It is also possible to zero or tare the sensor before a test by touching the main display area.

The controller will take into consideration the weight of the accessories (handle, hook, tray,...) fixed on the sensor rod. The total weight of the accessories on the sensor must not exceed 20% of the capacity of the sensor to be able to make the tare. The tare resets all the values in memory (maximum, calculations) and also resets the outputs.

NOTE: At startup, the Centor Touch performs several self-tests to check the sensor status. Tools can be left attached to the sensor, but the total weight should not exceed 5% of the sensor's maximum capacity.

4.5. Backlighting

When you use the controller, the backlight will automatically turn off after a preset time of inactivity - see the "maintenance" chapter for settings.

5. Start your measurements

After setting up the Test menu, the T-Drive allows you to plot the curve of your tests. The following screen is displayed at startup. See the chapter "Configuring the graph and tests".

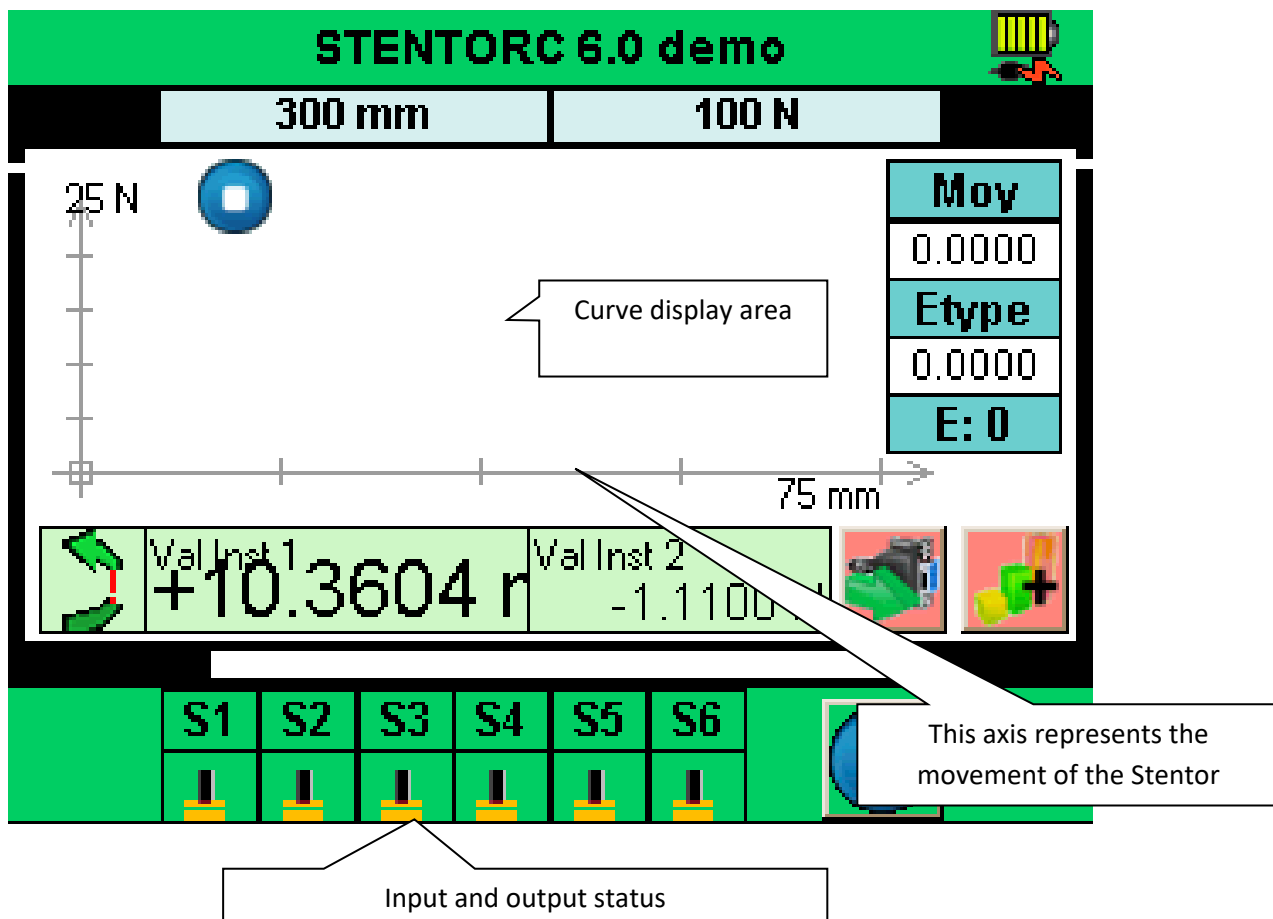

5.1. Start a measurement

By default, the T-Drive is configured to display the force vs. displacement curve. To start a measurement, simply press and hold the green Start button. The Centor Touch Dual will then reset the force and displacement to 0 and the frame will start moving in the direction configured in the Drivepack.



The force vs. displacement curve will then start to appear on the screen as the force increases.

The graph displayed is self-adjusting during the test. There are 3 values for the graph scale: 25%, 50% and 100%. At the end of the test, the graph is automatically retraced to make efficient use of the available space. The measured values can be positive or negative.

5.2. Status indicator

At the top left of the graph, a status indicator for the Centor Touch Dual is displayed:



The system is waiting, the curve has not started but the zero is done



The system is in acquisition, it draws the curve.



The test is finished. To start another test, it is necessary to make a zero.

If you wish to stop a test before the end of the test time, you can press this status indicator which will then switch from acquisition mode to Stop mode. This will not, however, stop the movement of the frame but only the acquisition.

5.3. Curve display area



There are 3 possibilities for the position of the axes: positive measurement, negative measurement and positive and negative measurement.

To begin plotting the graph, you must first press the green Start button to make a zero. When the CENTOR TOUCH detects an increase in force on the sensor, it will begin to plot the curve.

The curve represents the image of the force exerted on the sensor, the current value is displayed in the main area, the displacement is displayed in the auxiliary display area. Depending on the configuration of the screen parameters.

The Centor Dual Touch has very fast electronics and an acquisition rate of 1000 Hz, however, for a better readability, it keeps in memory a maximum of 1000 points of a graph.

The acquisition of a more accurate graph via continuous communication with the CALIFOT software and the USB output is done at 1000 values per second (adjustable parameter).

At the beginning of the curve, the indicator changes from  à 

To stop the acquisition, touch the graph area. However, the acquisition stops automatically after the time selected in the configuration screen. See [Configurer le graphique et les essais](#).

At the end of this acquisition, the status indicator changes to : 

At this stage, you can:

- Read the graph

- Record the values calculated during the test by touching the statistics window.
- Download the calculated values or the graph to a PC through the RS232 output (send data using the "key")
- Enter the configuration mode and modify the configuration
- Clear the chart by touching the main display area

To retest, use the green Start button to tare.

To change the configuration, touch the graph area.

6. Change the displayed information

The settings can be changed via the setup menu by touching the green information bar at the top of the main screen. Then touch the "Display" icon at the top left to change the display of the measurement screen.

The configuration screen appears as follows. Each parameter is used to configure the main measurement window. Each parameter is detailed below.

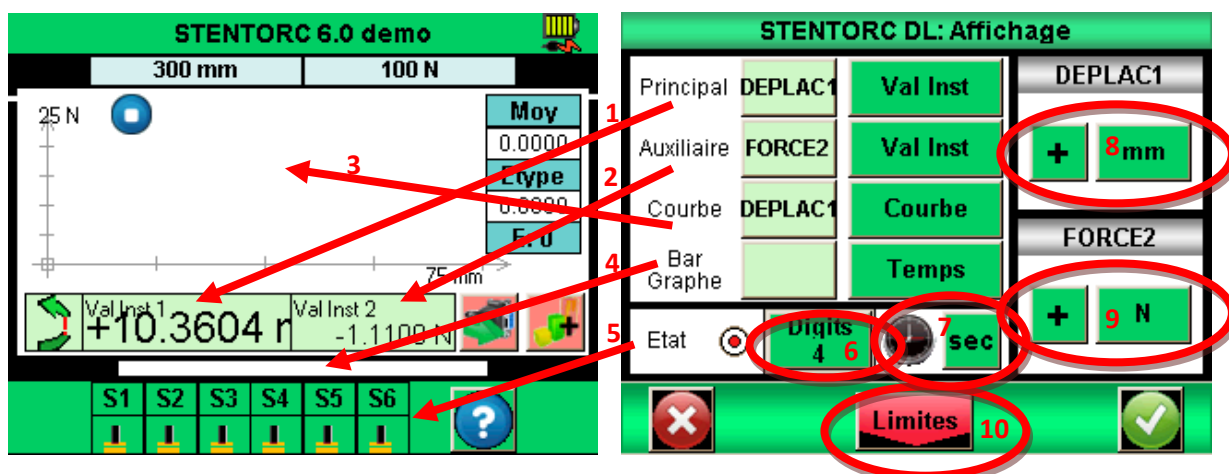

1. Main display window: The main display window can show all the values that appear in the list. Touch this value to display the list of available values. Choose the sensor whose value you want to display by touching the green window (DEPLAC1: displacement or FORCE2: force).
 - The data available are: Current value, Peak (maximum), Minimum and Calculation1 or calculation2 (if activated, see chapter: "How to setup Calculations" for the different calculations).
2. Auxiliary window: same as the main display window
3. Curve window: you have three possibilities:
 - Display the curve and two values: select 'Curve' (as in the figure above).
 - Display two values but no curve: select 'None'.
 - Display a third value but no curve: select the value to display.

When the curve is not displayed, the bar graph always represents the time.
4. Bargraph: allows you to set on which sensor and which value the Bargraph varies. The parameters are the same as for the main display.
5. Status : allows you to show or hide the status bar of the digital outputs of Centor Touch
6. Digits : number of decimals after the decimal point displayed during the measurement. Adjustable from 0 to 4.

7. Allows you to change the unit of time for setting the Centor Touch and the graph by touching the green box. The units available are milliseconds, seconds and minutes.
8. Unit and sign of displacement: Allows to change the unit of the sensor. The green button allows to change the sign of the displayed value: positive, negative or absolute value (the TEST menu must be deactivated to change this parameter)
9. Unit and sign of the force: same as displacement channel, but the unit values can change according to the type of sensor connected (force, torque, displacement, angle...), (the TEST menu must be deactivated to change this parameter).
10. Allows you to access the menu for setting the 'limits', see section "Adjust thresholds".

7. Set a limit or thresholds

You can access the limits and force threshold settings by touching the Bargraph on the main measurement screen or by touching the "Limits" button on the Display menu. The limit function of Centor Touch allows you to perform an action depending on the conditions of the value read by the sensor. These actions can be: change the color of the screen, activate a beep, stop the frame,...

7.1. Activate / Deactivate

Touch the "Enable" or "Disable" area to turn the limits on and off



7.2. Sensor tab

You have 2 tabs to display the configuration screen for each sensor (force or displacement). You can set up separate limits on each sensor. Select the tab for the desired sensor. Press the tab to enable or disable the limit function.

7.3. Choice of the value to which the limit applies

It is possible to define in Centor Touch on which type of value you want to put a limit. Generally, the instantaneous value is used. But it is also possible to set a limit on the maximum or on a calculation (average, derivative, break...see chapter: "Setup calculations").

Choose the data on which you want to set a limit by touching the field 3 to display the list of possible values.

7.4. Setting limit values

You can set a lower and upper limit for each sensor by touching the button, then enter the desired value using the keyboard.

You can then define if you want to have a beep when the measured value exceeds the defined limit.

The limit values will be automatically displayed on the graph and the Bargraph during the measurement. During the test, the measured value changes color when a limit is passed.

7.5. Stop the building on a limit

You can stop the frame when it reaches a force limit for example. Once the limit value is entered. You must activate an output of Centor Touch (S1 or S2) to send a signal to the Drivepack motor control. You must then modify the Drivepack configuration to set Action Ext 1 or 2 corresponding to S1 or S2 to "Stop".

Operation:

- If the low limit is configured only, the output will change state when the measured value is higher than the limit value.
- If the low and high limit are configured, the output will change state when the measured value goes between the limits.

Example of a T-Drive stop configuration on a 40N force:

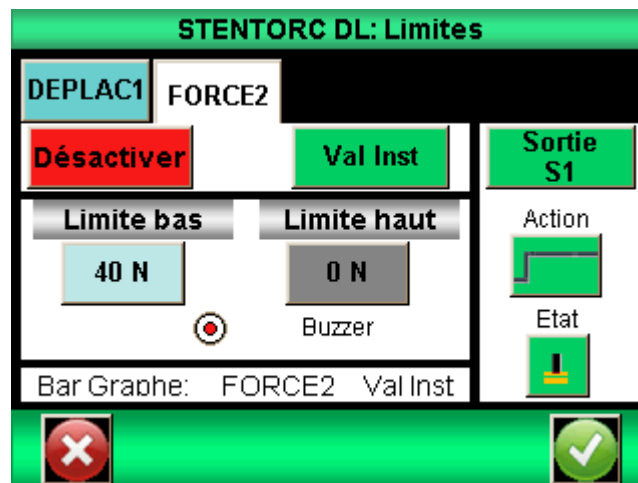

Drivepack Order Setup:

| |
|-------------------------------|
| <p>Action Ext. 1 Stop</p> |
|-------------------------------|

8. Set up the graph and the tests

To configure the graph and the test settings, go to the main menu and touch the Test icon on the screen:

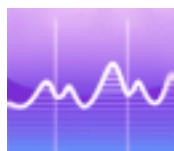

The graph configuration screen is displayed

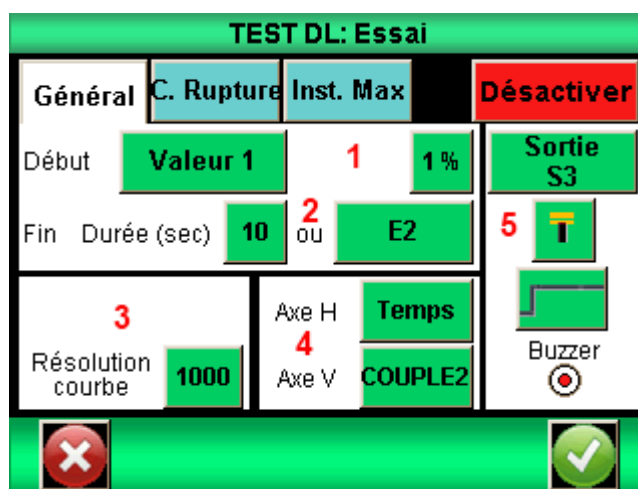

8.1. Test tab

Touch the area at the top right to turn the graphic on or off.

8.2. Configuration of test conditions

There are 2 parameters to consider when setting up a trial:

- The starting condition of the test
- The duration of the test

8.2.1. Start of the test

Once the sensor is tared, the Centor Touch waits for an event to start the acquisition. This event can be of two types:

- Variation of the value on one of the connected sensors
- External action (controller START button, external foot pedal or command via CALIFORT software)

Choose the test start condition by touching the green area (Value 1 for the displacement sensor, Value 2 for the force sensor). "The pedal" corresponds to the green button on the front of the T-Drive controller.

If you have chosen Value 1 or Value 2, you must then define the percentage of the sensor's capacity that triggers the acquisition. For example, if the sensor has a capacity of 100N and the percentage is set to 1, the test graph starts when the force reaches 1% of 100N, i.e. 1N.

Touch the % button and then set the desired value using the keyboard on the screen.



8.2.2. End of the test

You must define the maximum duration of a test in order to allow the controller to record the values during your test. This maximum time has an influence on the resolution of your curve. For example, if you have defined a duration of 10 seconds and the resolution of the curve is 1000 points, you will have one point recorded every 0.01 second.

Set the maximum time for the test by touching the green box next to Duration. Then enter the desired value using the keyboard.

Note: a test can be interrupted before the end of the set time by touching the  icon during the test or by using a discrete input of the controller. See chapter: "Input / output". The green button to the right of the time allows you to select a discrete input. However, stopping before the end of the test will not modify the resolution of the curve calculated at the start. However, there will be fewer points recorded. For example, if the duration of the test is 10 seconds and the resolution is 1000 points, the controller records one point every 10ms. If the test is interrupted after 5 seconds, the number of points of the curve will be 500 and the resolution will still be 10ms

8.2.3. Resolution of the curve

The recording resolution of the curve can be changed. By default, it is set to the maximum: 1000 points.

The resolution of the curve indicates the number of points recorded during the test. However, this value is not simply a sampling rate. In reality, the acquisition frequency on the internal sensor is 5000Hz, so the controller averages all the values read from the sensor and records this average as a function of the curve resolution.

Example: Resolution of the curve 1000 points, duration of the test 10 seconds. Therefore recording of one point every 10ms.

The controller will then average the values read on the sensor at 5000hz and record this average every 10ms. Therefore, the first value recorded will be the average of the force between 0 and 10ms, the second between 11ms and 20ms etc....

8.2.4. Display axes

You can choose what you want to display on the horizontal and vertical axis of the graph: time, displacement, force. Touch the green squares to change the values. This allows you to display, for example, the force as a function of time.

8.2.5. Perform an action at the end of the test

At the end of the trial you can perform two types of actions:

- Beep: Activate or deactivate this function by touching the circle below "Buzzer".
- To activate a digital output of the controller: choose the output to be activated (from 1 to 6) and the operating mode: pulse or toggle as well as the high or low state. More details on the digital inputs / outputs in the chapter: "Input and Output".

9. Setup calculations

The Centor Touch offers the possibility of automatically carrying out calculations on the measured values. The setting of these calculations is done in the Test menu. It is possible to carry out 2 calculations simultaneously in addition to the display of the instantaneous value, the maximum and the minimum.

9.1. Choice of calculations

The Centor Touch allows you to select 2 calculations, made from the graph. Access the configuration of each calculation by touching the calculation tabs. The Test mode must be activated to perform calculations.



The available calculations are :



1^{er} Peak: Calculates the first break detected by the sensor. You can define on which channel the calculation is performed and the percentage of force drop from the maximum that will trigger the calculation. Any other break after the first one will be ignored.

C. Breakage: Calculates the value of the breaking force during a test. Defined as a percentage of the maximum of the curve.

Contact force: Calculates the force at the moment of closing a contact or a switch connected to the E1 input of Centor Touch.

Force at T : Calculation of the force at a time T defined in relation to the beginning of the test

Inst Max: Calculates after how long the maximum has occurred during the test.

Max: Calculates the maximum between two defined times.

Sliding average : Calculation of the sliding average over a defined number of points.

Average: Calculation of the average of the values between two defined times.

Breakage level: Calculation of the value of one of the channels when the value of the breaking force has occurred. This calculation is only available in the second calculation, when the rupture calculation has been chosen as the first calculation. This calculation is done in relative or absolute value.

Level N: Calculates the value of one of the channels when the other channel reaches a defined value. This calculation is done in relative or absolute value.

Stiffness: Calculation of the slope of the curve between two values.

Speed: Calculation of the real time speed of the selected lane.

9.2. Action following a calculation

After each calculation it is possible to activate an output of the controller. Choose the output to be activated (from 1 to 6) and the operating mode: pulse or toggle as well as the high or low state. More details on the digital inputs / outputs in the chapter 'Input and Output'.

10. Storage of results and statistics

Centor Touch has a memory for 200 results and automatically calculates the average, the standard deviation and the average divided by the standard deviation of these results. It is possible to put in memory 3 results simultaneously among the maximum, the minimum, the calculation 1 and the calculation 2.

Note: The controller cannot store curves. Only one curve is saved inside the controller. You must connect the controller to a computer or use our DATASTICK USB memory recorder to save multiple curves.

To access the statistics configuration, touch the following icon from the main menu:

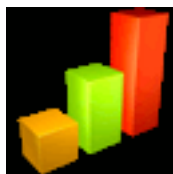

10.1. Statistics configuration



Using the buttons in zone 1, you can choose the 3 types of value you wish to save: minimum, maximum, calculation 1 or calculation 2 for each channel. Then select the desired unit of measurement.

You can then configure the number of samples you have available.

By default, the tare is performed automatically after each save, but you can disable this automatism.

You can then consult the tables of values by touching the "Table" button, and the calculations by touching the "Result" button.

10.2. Save values

When the statistical mode is activated, the following icon appears on the main measurement window to the right of the result windows.



To save the data in the memory, start a trial by making the tare. At the end of each trial, press the icon above to validate the trial and save it. The values stored in memory are added to the table of values and the average is then recalculated and displayed in the statistics window at the top right of the screen.

| |
|--------------|
| Moy |
| +5.04 |
| Etype |
| +1.50 |
| E: 4 |

To view all the calculations and values in memory, touch the window. It is possible to transfer these results to a computer. See [Communication avec un ordinateur](#).

TOUCHST ST: Résultats

Maximum
FORCE1

| | |
|-----------------------|--------|
| Moyenne | +5.04 |
| Ecart Type | +1.50 |
| Moyenne / Ecart Type | 334.88 |
| Nombre d'Echantillons | 4 |



Retour **Tableau**

TOUCHST ST: Tableau

Maximum
FORCE1

| N | Valeur (N) | Date/heure |
|---|------------|------------------|
| 1 | +6.07 | 08/07/2014 11:28 |
| 2 | +2.44 | 08/07/2014 11:28 |
| 3 | +5.89 | 08/07/2014 11:29 |
| 4 | +5.79 | 08/07/2014 11:30 |

Retour **Résultat**

11. Communication with a computer

It is possible to connect the controller to a computer or a system with an RS232, USB or analog input.

To access the communications configuration menu, from the main menu, touch the following icon:



The following window will appear:

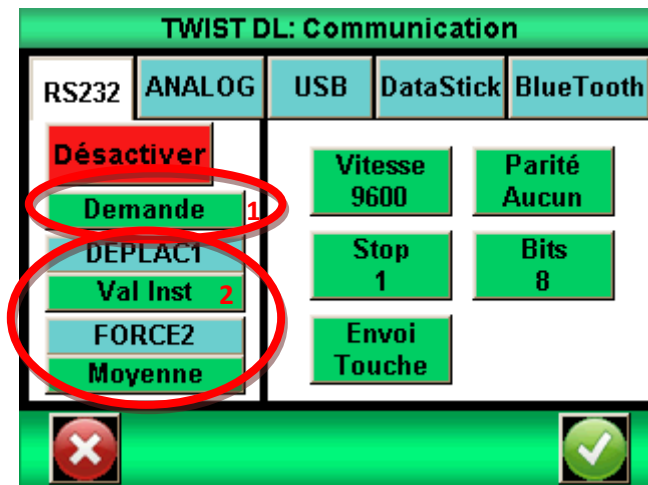

Note: One and only one of the five choices for data output is available at a time. Select the corresponding tab for RS232, Analog or USB.

The outputs of the Centor Touch have the following functions:

- RS232: continuous data transmission at 100Hz, data transmission on demand via the screen, a digital input or a computer, transmission of the stored curve.
- USB: continuous data transmission up to 1000 Hz, data transmission on demand via display, digital input or computer, transmission of the stored curve.
- Bluetooth: continuous data transmission at 100 Hz, data transmission on demand via display, digital input or computer, transmission of the stored curve.
- Analog: continuous data transmission at 100 Hz
- Data Stick: send data on demand via the screen to the USB memory.

11.1. RS232 or Serial link

The RS232 input/output can be set to two modes:

- Continuous: Sends the measured data continuously via the serial link, with a frequency around 100 Hz. (Configuration mode required to use Andilog Caligraph and Califort software)
- Request: A command must be given to the controller to send data. This command can either be sent by a computer with ASCII characters via the serial link (see list below of commands), or by using a discrete input of the controller, or by using the icon below located on the measurement screen.



If you want to send data on a screen command or an input, choose the type of command by touching the green button in zone 1.

Note: The data proposed in zone 1 are dynamic. Therefore, if the two controller inputs are used for other operations, they will not appear in the menu. Only the available inputs appear. See chapter: « Input and output » for more details.

Finally, choose the type of data to send:

- If you wish to send the command via the display or an input, also choose by means of the green button in zone 2 which type of value you wish to send: instantaneous value, maximum, minimum, calculation 1 or calculation 2, and the sensor.
- If you want to send the command via computer, the value returned by the device will depend on the ASCII character sent by the computer.

Set the speed, parity, stop bits and the number of bits corresponding to the connected computer. By default the values are :

- Speed : 9600
- Parity : None
- Stop : 1
- Bits : 8

If you wish to send serial commands using a computer, you can either use our dedicated RSIC software or use the following ASCII characters:

- F : current value of sensor 1
- I : current value of sensor 2
- P : maximum value of sensor 1
- M : maximum value of sensor 2
- V : minimum value of sensor 1
- B: minimum value of sensor 2
- C: calculation
- T: last 2000 calculated values
- U : unit of sensor 1
- N : unit of the sensor 2
- W: The last graph

- Z: Tare

The communication protocol follows the following rules in "Request" mode:

- The controller sends the character RC (13 decimal, 0D hexa) at the end of the string
- The controller sends the sign +, - or nothing depending on the measured value and the configuration
- The number of characters sent varies according to the capacity of the sensor and the position of the decimal point
- The force and displacement data are separated by a space
- The controller returns "?" if he does not understand the request
- The controller returns "!" if the corresponding result is empty.

11.2. USB connection

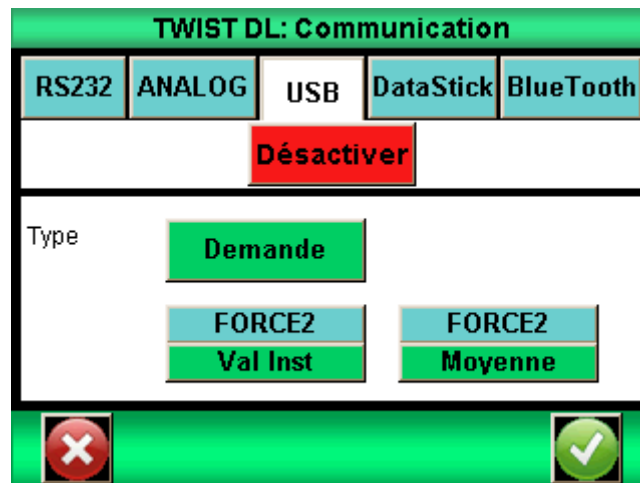

The USB connection creates a virtual communication port on the connected computer. It has the same functions as the RS232: request and continuous mode. The commands also remain the same.

The differences with the RS232 mode are:

- Possibility of setting the frequency of continuous transmission of values if the "Eco" mode is activated in the "General" menu
- The baud rate is fixed and set to 921600 bauds/s

11.3. Bluetooth link

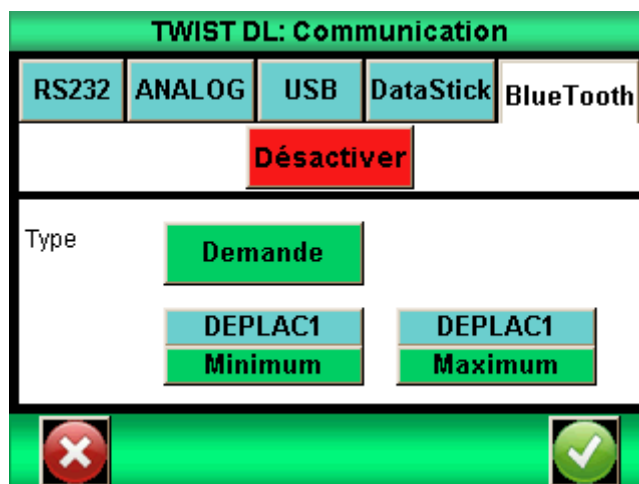

The Bluetooth link allows wireless communication with a computer. It allows to replace for example a RS232 or USB cable. It requires a module sold separately that plugs into the connector on the side of the Centor Touch.

The Bluetooth link has the same functions as the RS232: request and continuous mode. The commands also remain the same.

11.1. Analog link

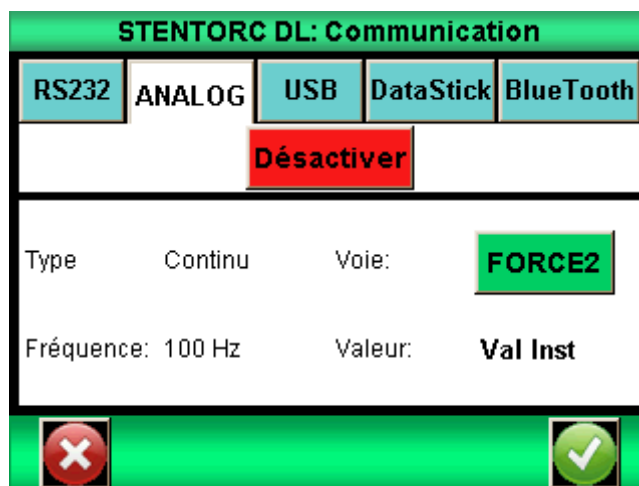

The Centor Touch can send analog data at a frequency of 100 hertz. The analog output is +/- 1V.

11.2. Data Stick (Option)

11.2.1. Configuration

The activation and configuration of the data stick is done in the "Communication" menu. Datastick allow you to save data on a USB stick. The USB plug is on the back of the DriveTouch.

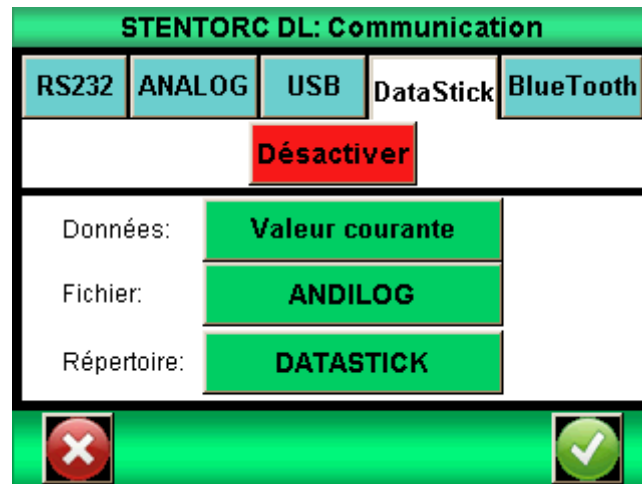

The Centor Touch can save different types of data on the USB stick. Choose the data to be saved among:

- Curve: Saves the curve displayed on the screen
- Curve and calculations: Saves the curve displayed on the screen + the max and min + the configured calculations
- Statistics: all the values stored in memory in the statistics of Centor Touch
- Current value: the value measured on the sensor at the time of transfer
- Calculated values: max, min and the calculations configured in the TEST menu

You can, if you wish, change the name of the file in which the unit data (statistics and values) will be saved. By default, the file will be called "ANDILOG". This name will be completed by the date of the day of the saving. Example: ANDILOG_2013_01_17.txt. Each new record will be added at the end of the file. Press the green button next to "File" to modify.

The directory is used to save the curves. Its name can be changed. By default it is called DATASTICK. This name will be followed by the date and time of the beginning of the curve. Example: "DATASTICK_20130117_094026". The directory will contain two files:

- data.txt : data of the curve
- testSettings.txt : setting of the curve plot

All of these files are in text format and can be opened in a Microsoft Excel-type spreadsheet to trace the curves or exploit the results.

The modification of a name is done by pressing the corresponding button. This triggers the display of a virtual keyboard:



All these files are in text format, the data are separated by the TAB character (09 decimal and hexadecimal) and the lines are separated by a carriage return (13 decimal, 0D hexadecimal).

11.2.2. Saving measurements

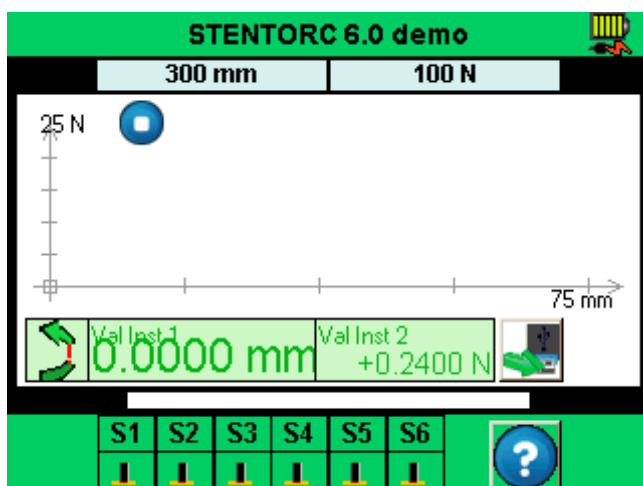

Once the Data stick option is activated, a USB icon appears on the measurement screen:

Saving is done by pressing the icon below located on the measurement screen:



During the reading and writing of data, the icon turns into an hourglass, indicating that the data stick must not be disconnected, otherwise it may be damaged. When the hourglass is not visible, you can plug and unplug the key.

11.2.3. Use multiple USB drives

The USB key provided by Andilog is associated with the Centor Touch serial number indicated at the time of the order and it cannot be used on another Centor Touch. Nevertheless, it is possible to duplicate the Andilog key if you want to have several keys for a Centor Touch.

To do so, you just have to copy the "Data Stick Config" file from the original key to another USB key. The Centor Touch is compatible with USB 2.0 keys.

12. Digital and pedal inputs and outputs

The Centor Touch has digital inputs and outputs that can be configured to allow the Centor Touch to communicate with the Drivepack inputs.

The Centor Touch has:

- 3 inputs (named: Pedal, E1 and E2)
- 6 outputs (named: S1 to S6)

The Drivepack features:

- 2 entries
- 1 output

Each input/output can be configured separately via the different menus and functions of Centor Touch (limits, calculations, communication...). A menu allows to know and configure the state and the assignment of each of them. This menu is in the " Maintenance " menu of the main menu. Then the third tab " TOR I/O " as shown below.

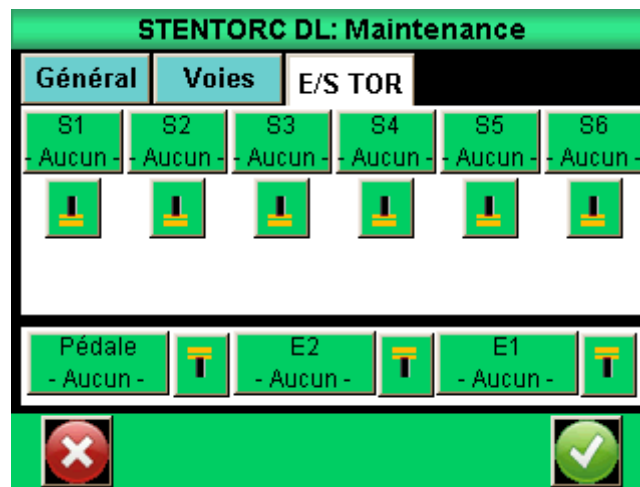

12.1. Centor Touch releases

Each output from 1 to 6 can be configured separately. These outputs can change state under different conditions depending on the controller settings. The main functions of state change are :

- None : no action
- Calculation 1 : changes state at the end of calculation 1
- Calculation 2 : changes state at the end of calculation 2
- End of trial : changes state at the end of a trial
- Limit : changes state when passing a limit (Channel 1 or Channel 2)
- DEP. 120% : changes state when the measured value exceeds the maximum capacity of the sensor by 20%. Used to protect the sensor if it is mounted on a motorized frame.

Outputs 1 and 2 are connected to Drivepack inputs 1 and 2 respectively

For each output it is possible to define whether the default value (at the start of the test) is high or low by touching the symbols below:



Moreover, it is possible to define for each output how it changes state:



- Toggle: the output changes state and remains on the new state as long as it is not reset to its original state at the beginning of a test or the condition is true (case of limits).



- Impulse : the output changes state for 50 ms then returns to its original state.

12.2. Inputs and pedal

The 3 digital inputs (Pedal, E1 and E2) of Centor Touch can be configured separately. These inputs allow the following operations:

- ACTIVE TEST: start a test
- STOP TEST : stop a test
- TARE VX : zero on channel 1 or 2
- F. CONTACT : used in the calculation of force measurement on contact closure.

The Pedal input is connected to the green button on the front of the T-Drive. By default, this input starts a test.

For each input it is possible to define whether the default value (at the start of the test) is high or low by touching the symbols below:



13. General parameters

The general settings of the Centor Touch can be accessed from the main "General" menu. These settings allow you to adjust the sounds, standby, language and screen orientation.

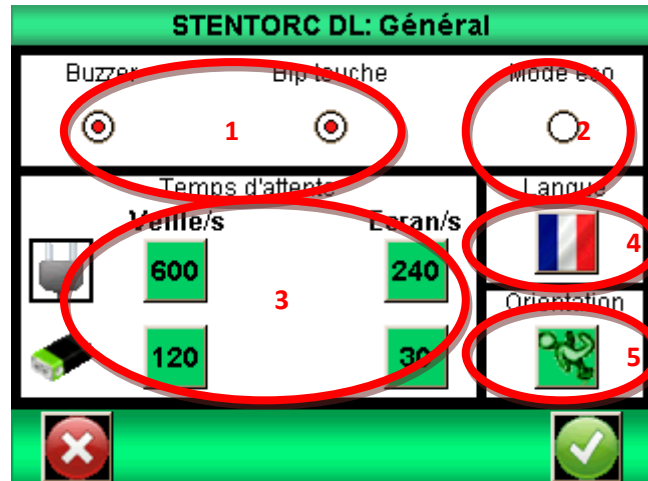

13.1. Sounds

Buzzer: Enables or disables the buzzer for alarm conditions

Key Beep: Enables or disables the beep when the screen is touched

13.2. Eco mode

Reduces power consumption. Useful for long test times.

13.3. Food management

The time for the screen to go to sleep and the time for the screen to be turned off can be set separately for battery and mains operation.

Standby /s: Sets the time of inactivity before the controller goes into standby. After a sleep mode, you must use the On/Off button to turn the unit back on. Touch the button and use the keyboard that appears to set the inactivity time in seconds.

Screen / sec: Sets the time of inactivity before the screen is turned off. Touching the screen turns the screen back on. Touch the button and the keyboard to set the inactivity time in seconds.

13.4. Screen orientation

The touch screen can be rotated in 90 degree increments. Touch the desired image to select the screen orientation.

13.5. Language

Touch the image and then the flag to select the desired language.

14. Maintenance

The maintenance screen provides access to basic settings and status information. Select the service symbol from the main menu screen.

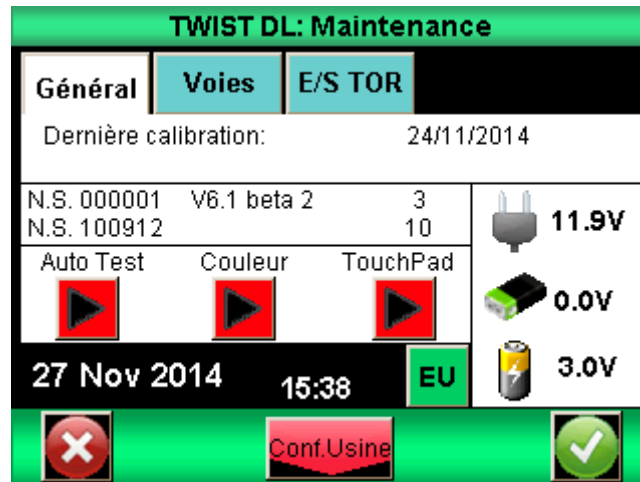

14.1. General

The General tab provides information about the sensor, the software version and battery status, and the time and date settings.

Auto test: launches a self-test and displays detailed information about the status of all connected sensors (offset, overload calibration) and battery conditions.

Color: Displays the basic colors to check the status of the screen.

Touch Pad: Allows calibration of the touch screen.

14.2. Setting the clock:

Date and time are set from the Maintenance tab. Touch the date format button below. This takes you to the date and time setting screen



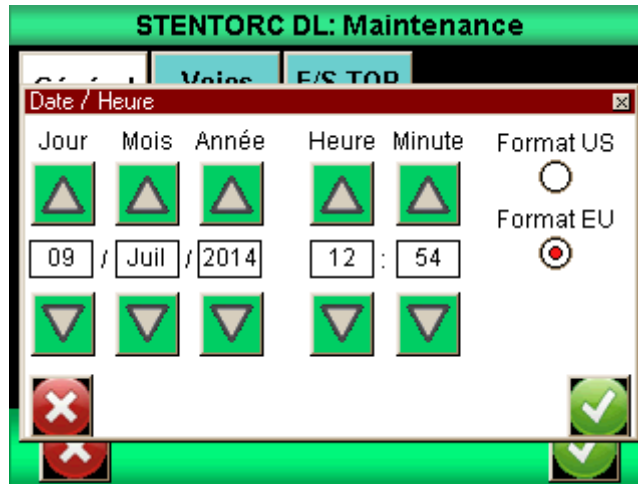

Change the date and time by touching the up or down arrows. You can also choose the format in which the date is displayed:

- EU = day - month - year
- US = month - day - year

14.3. Pathways

Displays sensor data details and current settings for all input and output signals.

14.4. Factory configuration

This function allows you to return your device to its factory configuration.

15. T-Drive configuration examples

The purpose of this chapter is to provide examples of typical force measurement setups with the T-DRIVE system (and without the use of CALIFORT software). It will allow you to simply set up your tests and to understand more easily how to set up other typical tests.

15.1. Protection against overflow

One of the most common problems encountered is configuring the system to shut down before damaging the sensor. Our sensors are protected up to 150% of their maximum capacity. However, the T-Drive has a feature that allows it to shut down at a pre-programmed limit when it exceeds 120% of the sensor's capacity.

Attention: stopping when reaching 120% of the capacity or on a limit close to the maximum capacity does not guarantee the protection of the sensor. It is necessary to take into account the fact that the frame has an inertia between the moment when the stop command is sent and the moment when the frame actually stops. This risk and the margin to be taken depend strongly on the speed at which the frame is used.

15.1.1. Protection at 120% of capacity

Go to the "Maintenance" menu, then "Digital I/O". You must configure the S1 or S2 output on "DEP.120%" depending on which one is not used.

Then for this input, make sure the status indicator is set to  and the signal type to pulse .

Then go to the Drivepack menu, to Input 1 if you have configured output 1 of Centor Touch or Input 2 if you have configured output 2 of Centor Touch and change its status to Stop

Entrance 1
Stop



15.1.2. Stop on a configurable limit

Go to the "Display" menu  and then press "Limits" .

In this example, we assume that we have a 100N capacity sensor and we want to stop when the force reaches 40N.

Touch the "FORCE2" tab, then choose "Val Inst".

Set "Low Limit" to 0N and "High Limit" to 40N.

Choose the "Output" to activate S1 or S2. Then choose the icon change of state  and finally high state 

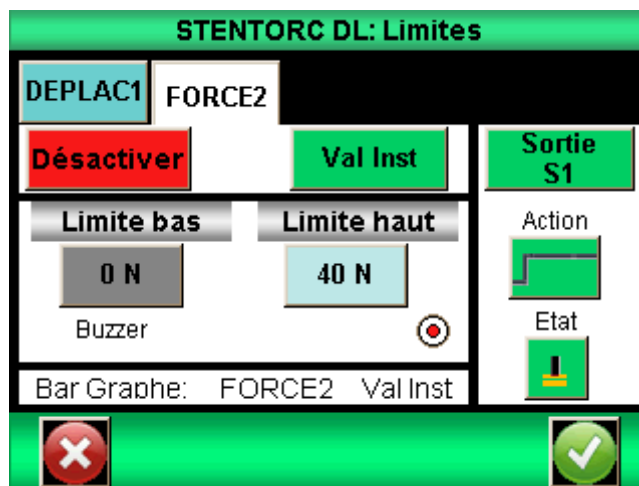

Then go to the Drivepack menu, to Input 1 if you have configured output 1 of Centor Touch or Input 2 if you have configured output 2 of Centor Touch and change its status to Stop

Entrance 1
Stop

Note: If neither S1 nor S2 are available in the proposed list, this indicates that they are already used for other actions. It is then necessary to go to the Digital I/O menu to reorganize your outputs.

15.1.3. T-Drive origin configuration:

Without putting a spring on the T-Drive, manually lower the frame to approach the table at high speed. Then with the slow speed, move the frame manually until the compression plate touches the table (display of a force > 0 on the Centor Touch). Be careful, the force can increase very quickly. Then press the button  to reset the T-Drive to 0.

Raise the stand by pressing the button . It will stop at 180 mm above the table.

Note: In order to take a slight deformation of the measuring system during the tests, it may be recommended to zero the displacement when the Centor Touch Dual displays a force equivalent to the value you wish to measure on the spring. It is recommended to do this operation at a lowering speed of 10mm/min to limit the risk of damaging the sensor.

15.1.4. Run the test:

Place the spring on the T-Drive below the compression plate. Press the Start button  until the frame starts to run the test. The T-Drive will then descend until it compresses the spring to a height of 90mm, stop, wait a second and then rise to its original position.

If you have configured RS232 on your T-Drive, press the  key to send maximum force and displacement.

15.2. Peel test

A peel test consists of separating two layers of a bonded material. Examples of peel tests are yoghurt pot opening, plastic bag opening, plastic welding tests... In general, the results to be obtained, outside the curve, are the maximum force (starting force) and the average force (peeling force).

In this example, we will configure the T-Drive to perform a pull at 80mm/min on 50mm of sample and display the maximum force and the average force between 5 and 25 seconds of testing (to eliminate the maximum and the end of the test from the average calculation)

15.2.1. Drivepack configuration

Speed 
80.00 mm/min

Speed 
200.00 mm/min

Goal. pos 
Inverter

Goal. pos 
50.00 mm

Goal. pos 
Stop

Goal. pos 
0.00 mm

Break 
0

Break 
1

Pedal
Dem Pos.

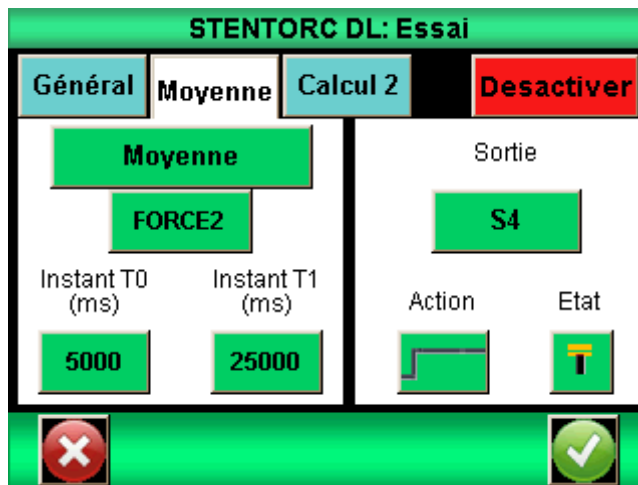

15.2.2. Configuration of the Centor Touch Dual

In the test menu, touch the "Calculation1" tab, then choose "Average" and FORCE2. Set Instant T0 to 5000ms and Instant T1 to 25000ms. Then validate.



In the "display" menu, choose "FORCE2" and "Peak" for the main display and "Force2" and "Average" for the auxiliary display.

15.2.3. Start the test

Make the 0 move on the T-Drive using the  key. Place your cable on the T-Drive. Press the Start button  until the frame starts to initiate the test. The T-Drive will then climb until the cable breaks. Stop after 50mm, then lower back down to its original position.

15.3. Cable breakage

These tests consist of measuring the force required to separate a terminal from a cable. The principle is that the T-Drive stops when the break is reached and then returns to its starting position. In this example, the traction is done at 50mm/min with return to the original position after the cable break.

15.3.1. Drivepack configuration

| |
|---|
| Speed  50.00 mm/min |
|---|

| |
|---|
| Speed  200.00 mm/min |
|---|

| |
|---|
| Goal. pos  Stop |
|---|

| |
|--|
| Goal. pos  0.00 mm |
|--|

| |
|-------|
| Pedal |
|-------|



| |
|---------|
| Entry 1 |
|---------|

Dem Pos.

Inverter

15.3.2. Configuration of the Centor Touch Dual

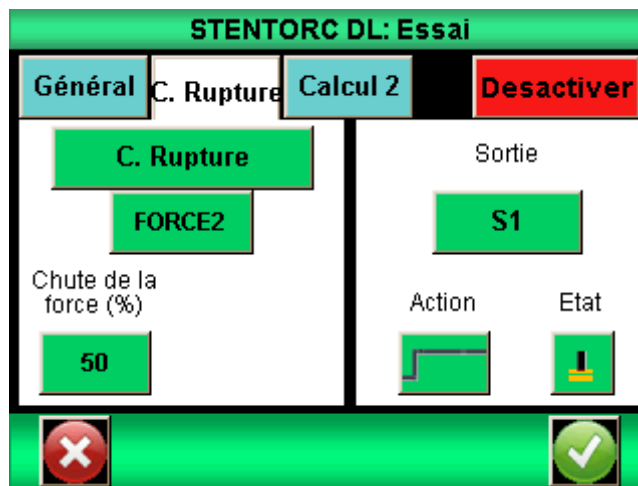

In the test menu, touch the "Calculation1 " tab, then in the drop-down menu, choose "Break" and FORCE2. Set the percentage of force drop to 50% for example.

Select "Output": S1 - Action:  - Status: 



In the "display" menu, choose "FORCE2" and "Rupture" for the main display and if you want to know the displacement at rupture "Deplac1" and "Pic" for the auxiliary display.

15.3.3. Start the test

Make the 0 move on the T-Drive using the  key. Place your cable on the T-Drive. Press the Start  button until the frame starts to initiate the test. The T-Drive will then climb until the cable breaks. Stop, then lower back down to its original position.

16. Annexes

16.1. Acquisition software

ANDILOG TECHNOLOGIES has developed several software programs to record and analyze the values of our measuring instruments. The CALIFORT software allows you to control your T-DRIVE testing machine, to set up several test configurations and to acquire your data (for analysis and test report edition). See the dedicated user manual.

16.2. Interface cables

The interface cables that can connect the DRIVETOUCH controller and your computer to use the CALIFORT software have been provided.

However, for a use without software you can use the following cables:

- External pedal: allows you to perform an action (start a test...) when you press the pedal.
- Cable for external contact: allows the controller to be connected to a switch for the calculation of the closing / opening force of contacts.
- RS232 link cable: connect your controller to a computer using the RS232 output
- USB cable: connect your controller to a computer using the USB output

16.3. Protector - Safety enclosure

If your T-Drive is equipped with a safety enclosure with a locking door, opening the door stops the T-Drive and disables the control. To access the menu and commands, you must close the door of the protector. When you close the door, the test bench will not resume the test in progress where it left off. You will have to restart your test from the beginning.

16.4. Error messages

16.4.1. Centor Touch display error message



This screen appears when a minor fault is detected when the instrument is started. Minor faults can be :

- Low battery
- Overloads detected below 10
- An outdated calibration date

Press the Measure button to continue.

If the Measure button does not appear: An error preventing the controller from operating has been detected.

Causes may include:

- Damaged sensor
- Number of overloads > 10
- Internal error
- Sensor not connected

16.4.2. Drivepack command error message

Drivepack has different error messages depending on the problem encountered.

If the Drivepack detects too much power consumption, the rack will stop and you will see the following message appear:

Dist+ 0.00 mm
CURRENT SECURITY

You must then shut down the system and restart it to cancel this error.

In addition, the T-Drive has internal travel stops that allow the frame to stop before it reaches its travel limits. These travel stops cut the power to the motor in the direction of travel. You can then move the frame manually using the Drivepack control in the opposite direction.

Note: After this type of stop the displacement value may be off. You must re-zero or check the displacement value before retrying

If the Drivepack controller cannot communicate with the T-Drive electronic board (e.g. if the cable is broken/damaged), both systems will shut down the motor and initiate a restart process. You will have to try to turn the frame off and on to cancel this error. It is then strongly recommended to consider a maintenance operation by contacting the ANDILOG Technologies team to know the modalities.

! SAFETY !
ERROR CODE # 6

If the system detects that a command is not performed correctly, it displays the following error message:

! SAFETY !
Door / Surch / Pos

In this case, you should check the following points:

- If you have a security door, make sure it closes properly
- If you have exceeded the capacity of the rack, remove the overload
- If the frame has reached a travel stop, move the frame in the opposite direction

If the system detects that a setpoint (e.g. travel speed) is not registering correctly, due to an internal communication cause, it displays the following message:

! SAFETY !
ERROR CODE # 2

This may occur if there is a loss of communication or unstable communication due to a wiring problem or a defective component. You will have to try to turn off and on the rack to cancel this error. It is then strongly recommended to consider a maintenance operation by contacting the ANDILOG Technologies team to know the modalities.

If the controller has communication problems with the Califort software, it displays the following error message:

**! SAFETY !
ERROR CODE # 5**

If the event is temporary, no action is required and manual control is active (after the operator's judgment).

In this case, you should check the following and restart the Drivepack:

- The 2 connection cables are well connected to your computer
- The length of the cables can be questioned, check that you use the cables provided by ANDIOG Technologies
- Check that the cables are not damaged
- Reactivate the communication from the maintenance interface

16.4.3. Fuses

If you cannot turn on the T-Drive, it is possible that one of the 3 protective fuses is out of order.

The first fuse is located on the side of the frame at the switch. It is a 5A fuse of 5x20mm.

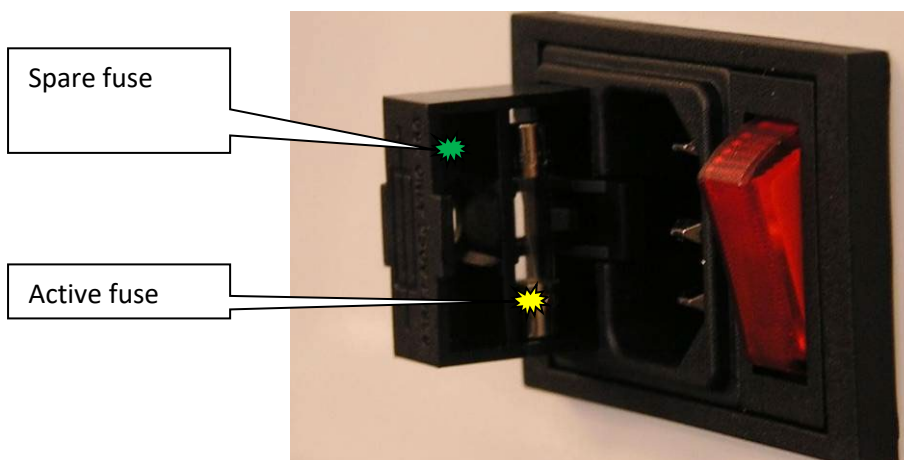

16.5. Factory configuration

Below are the configuration screens when the controller is delivered:

16.5.1. Display

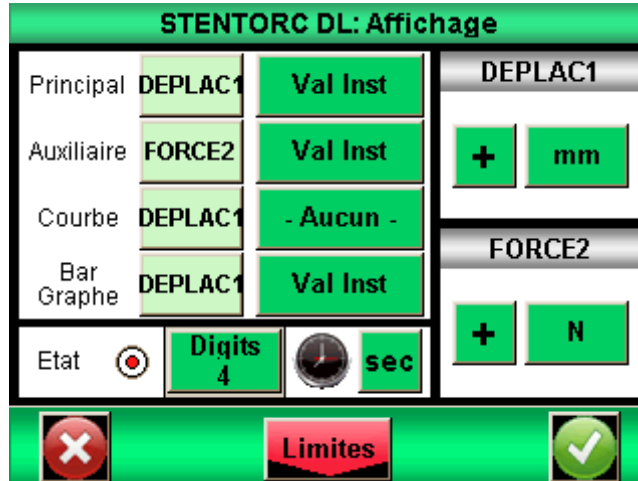

16.5.2. Test



16.5.3. Statistics

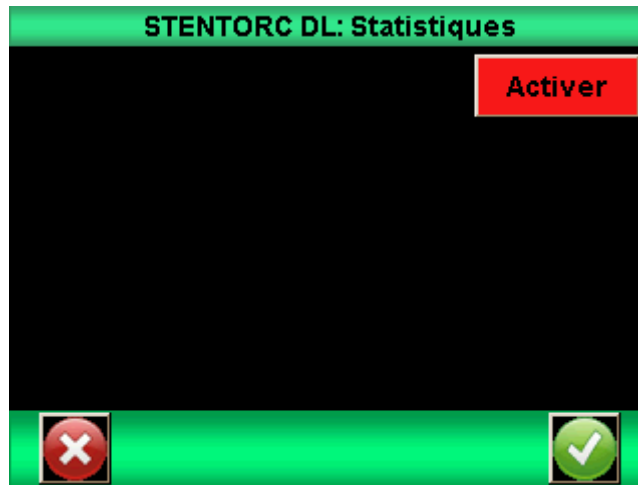

16.5.4. Communication

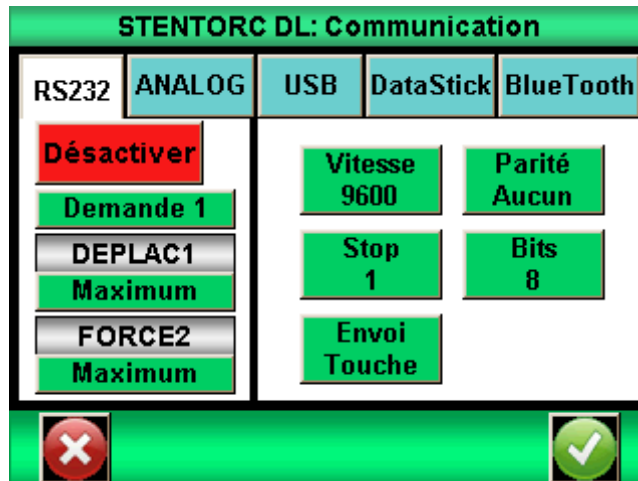

16.5.5. General

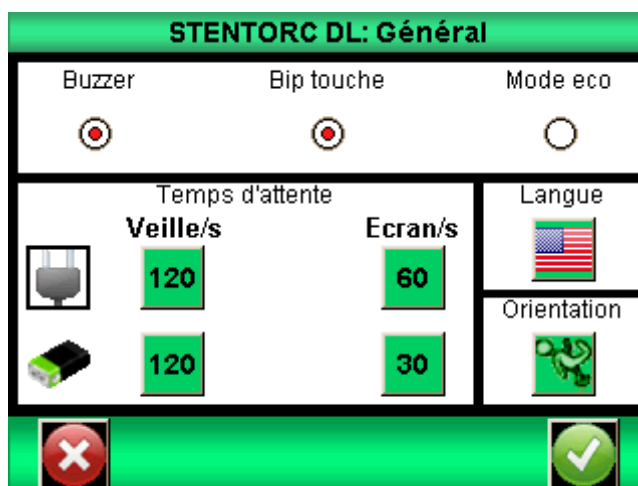

16.5.6. Maintenance

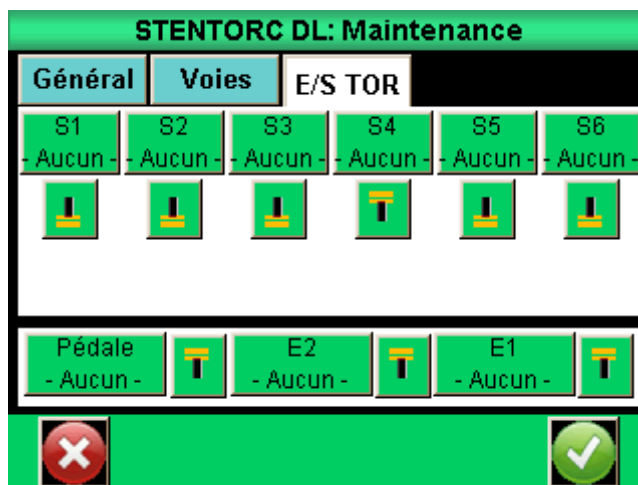

16.6. Connections

The DriveTouch controller of the T-Drive has 2 connectors on the right side. The 15-point connector is connected to Drivepack and the 26-point connector is connected to Centor Touch Dual.

Note that the pedal inputs of the Drivepack and Centor Touch are wired together and that output 1 and output 2 of the Centor Touch are connected to inputs 1 and 2 of the Drivepack.

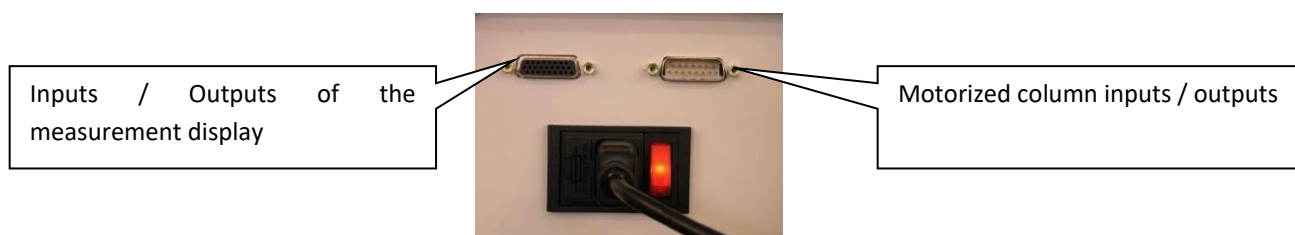

16.6.1. 26-point Centor Touch Dual connector

| | |
|----|---------------------------|
| 1 | Mass |
| 2 | Input E1 |
| 4 | RS232 reading |
| 5 | USB device data, negative |
| 6 | USB host data negative |
| 7 | Output S3 |
| 8 | Output S2 |
| 9 | Reset |
| 10 | Analog output |
| 11 | Input E2 |
| 14 | USB Device Power supply |
| 15 | USB Host Power supply |
| 16 | Output S4 |
| 17 | Output S5 |
| 18 | Mass |
| 19 | Earth |
| 20 | Pedal input |
| 22 | RS232 transmit |
| 23 | USB device data Positive |
| 24 | USB host data Positive |
| 25 | Output S6 |
| 26 | Output S1 |

16.6.2. 15-pin Drivepack connector

| | |
|----|----------------|
| 1 | Mass |
| 2 | Security input |
| 3 | Input 1 |
| 5 | Exit |
| 9 | Mass |
| 10 | Input 2 |

16.7. Dimensions

| | | |
|----------------------------|-----------------------------|----------------------------|
| CAPACITY: | 1000/ 2000/ 4000 lbs | 5/ 10/ 20 KN |
| TRAVEL: | 20/ 30/ 40 in | 508/ 762/ 1016 mm |
| WEIGHT: | 82lb/ 88lb/ 94lb | 37/ 40/ 43 KG |
| HEIGHT (A): | 38/ 48 / 58 in | 965/ 1219/1473 mm |
| MAXIMUM HEIGHT (B): | 60/ 80 /100 in | 1524/ 2032/ 2540 mm |

DIMENSIONS TABLE

| | | |
|-------------------------|-------------------|---------------|
| WORKABLE WIDTH: | 8 in | 203 mm |
| THREAD ON TABLE: | M12 x 1.75 | |

